

## OPERATING INSTRUCTION MANUAL

### USER INFORMATION

FOR

TRANSPORT

INSTALLATION

OPERATION

MAINTENANCE

and SAFETY

of

**IGW - FANS and ACCESSORIES**

**of the MANUFACTURER**

**WITT GROUP**  
**Witt & Sohn AG**

Ziegeleiweg 38  
25421 Pinneberg  
Germany  
Tel: +49 4101 7007-0  
Email: [request@wittfan.de](mailto:request@wittfan.de)  
Web: [www.wittfan.de](http://www.wittfan.de)

**WITT GROUP**  
**MEIDINGER AG**

Landstrasse 71  
4303 Kaiseraugst  
Switzerland  
Tel: +41 (61) 4 87 44 11  
Email: [info@meidinger.ch](mailto:info@meidinger.ch)  
Web: [www.meidinger.ch](http://www.meidinger.ch)

**WITT GROUP**  
**Fan Systems**

Witt House, Shelf Mills  
Wade House Road  
Halifax HX3 7BJ, Great Britain  
Tel: +44 (12 74) 69 49 99  
Email: [sales@fansystems.co.uk](mailto:sales@fansystems.co.uk)  
Web: [www.fansystems.co.uk](http://www.fansystems.co.uk)

**WITT GROUP**  
**Witt India Pvt. Ltd.**

8-2-293/82/L/352/A, MLA COLONY,  
ROAD NO.12, BANJARA HILLS,  
HYDERABAD-500034, TELANGANA  
INDIA  
Tel: +91 (40) 35 10 23 23  
Email: [info@wittindia.com](mailto:info@wittindia.com)  
Web: [www.wittindia.com](http://www.wittindia.com)

hereinafter abbreviated to 'WITT GROUP'

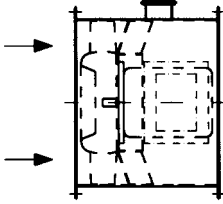
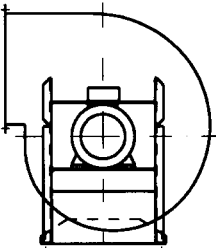
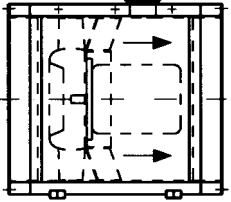
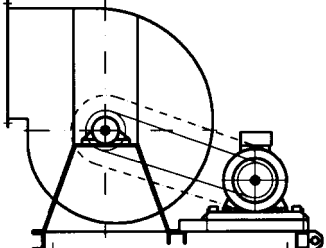
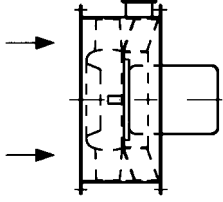
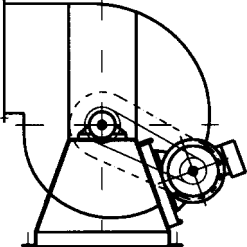
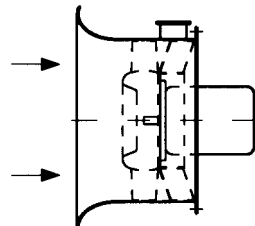
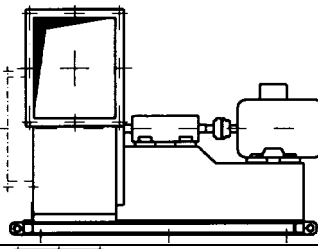
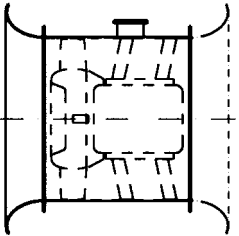
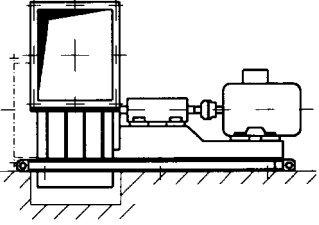
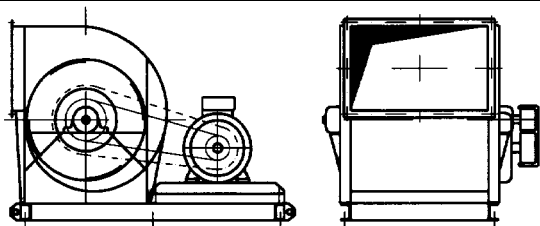
The latest version of this operating manual can be accessed on the internet from the website [www.wittfan.de](http://www.wittfan.de) under Downloads\Documentation.

---

## Table of Contents

Content	Page	Content	Page
Commonly used designs of axial-and centrifugal fans .....	3	<b>13. Electric motors</b> .....	<b>23 - 25</b>
Preface .....	4	13.1 General .....	23
<b>1. Transport und Transport advice</b> .....	<b>4</b>	13.2 Intended use .....	23
<b>2. Delivery / Installation of Axial- and Centrifugal fans - General</b> .....	<b>5</b>	13.3 Installation/mounting .....	23
<b>3. Installation instruction according to 2006/42/EC</b> .....	<b>5</b>	13.4 Electrical connection .....	24
<b>4. Commissioning</b> .....	<b>6-8</b>	13.5 Operation .....	25
4.1 Mechanical safety .....	7	13.6 Minimum speed/maximum speed .....	25
4.2 Fan with belt drive .....	7	13.7 Starting/stopping/reversing .....	25
4.3 Systems with dampers-/flap trap-Fire valves .....	7	13.8 Drain plug for condensation .....	25
4.4 Simultaneous operation of multiple fans .....	7	13.9 Transport, storage .....	25
4.5 Stall / anti-stall device .....	7	<b>14. Tunnel-fans</b> .....	<b>26+27</b>
4.6 Maximum speed, different speeds and speed control .....	7	14.1 Description .....	26
4.7 Motor protection switch .....	7	14.2 Mounting .....	26
4.8 Starting couplings .....	7	14.3 Common mounting errors .....	27
4.9 Explosion proof fans .....	7	14.4 Marking .....	27
4.10 Torque figures of bolts .....	7+8	14.5 Operation: Starting, stopping/reversal .....	27
<b>5. Maintenance</b> .....	<b>8 - 14</b>	14.6 Operational safety .....	27
5.1 Surface protection .....	8	14.7 Recommended Safety checks .....	27
5.2 Monitoring vibrations .....	8	<b>15. Flexible ports</b> .....	<b>27+28</b>
5.3 V-Belt drive .....	8	<b>16. Vane controller</b> .....	<b>28+29</b>
- Checking intervals und pretension for V-belt drives .....	8	16.1 Safety aspects .....	28
5.4 Flat belt drives .....	9	16.2 Installation .....	28
5.5 Bearings .....	9	16.3 Commissioning .....	28
5.5.1 Monitoring of bearings .....	9	16.4 Functioning .....	29
5.5.2 Additional instructions for various fan bearing types .....	10	16.5 Maintenance .....	29
5.5.3 Additional notes motor bearings / pillow block bearings .....	10	<b>17. Fire dampers/Battery doors</b> .....	<b>29+30</b>
5.5.4 Grease quality, quantity and lubrication intervals .....	11	17.1 Safety aspects .....	29
5.6 Shaft seals for gases and fluids .....	11	17.2 Transport .....	29
Shaft seals .....	12	17.3 Installation .....	29
5.6.1 Mounting the seals: Type-WDK .....	13	17.4 Function and commissioning .....	29
5.7 Mechanical starting couplings .....	13	17.5 General maintenance .....	29
5.8 Impeller inspection / Material fatigue .....	13	17.6 Special instructions for maintenance .....	29
5.9 Dismounting and refitting of impellers refer chapter 8 and 9 .....	13	17.6.1 Fire dampers/ battery doors with manual activation .....	29
5.10 Additional conditions for extended warranty (>12 months) .....	13	17.6.2 Fire dampers/ battery doors with fusible link .....	29
5.11 Troubleshooting .....	14	17.6.3 Fire dampers/ battery doors with pneumatic opening .....	30
5.12 Disposal .....	14	17.6.4 Fire dampers/ battery doors with electrical opening .....	30
<b>6. Instructions for storage and prolonged downtime</b> .....	<b>14</b>	<b>18. Cabin fans</b> .....	<b>30</b>
6.1 Precautions against unwanted power supply .....	14	<b>19. Booster blowers for combustible gases</b> .....	<b>30</b>
6.2 Long term storage .....	14	<b>20. Fans with motor coupling fan shaft</b> .....	<b>30</b>
6.3 Start-up after long term storage .....	14	<b>21. Non-abrasive fan heads</b> .....	<b>31</b>
<b>7. Storage specification for spare-, reserve-and abrasive parts</b> .....	<b>15</b>	21.1 Fan heads without fan .....	31
<b>8. Fitting instruction for Impeller-extraction device (Axial / Radial)</b> .....	<b>15</b>	21.2 Fan heads with fan .....	31
<b>9. Fitting instruction for impellers and belt drives with taper lock bushes (Axial / Radial)</b> .....	<b>16</b>	<b>22.1. Commissioning protocol</b> .....	<b>32</b>
<b>10. Special instructions</b> .....	<b>16- 18</b>	<b>22.2 Status- and maintenance protocol</b> .....	<b>32</b>
10.1.1 Operation at higher temperatures (> 70°C) / Smoke-proof design F200 / F300 / F400 (EN 12101-3) .....	16	<b>23. Fundamental safety instructions for products and components of the WITT GROUP companies</b> .....	<b>33 + 34</b>
10.1.2 Smoke control fans .....	17	23.1 Principle, intended use .....	33
10.2 Gas-tight fans .....	17	23.2 Organizational measures .....	33
10.3 Frequency converter / softstarter / speed regulation .....	17	23.3 Selection of personnel and qualification; basic duties .....	33
10.4 Thermal safety .....	17	23.4 Safety instructions for certain specific operational phases .....	33
10.5 Fans according to pressure-devices guideline 97/23/EG .....	17	23.4.1 standard operation .....	33
10.6 ATEX-fans – general instructions, additional standards and instructions .....	17 + 18	23.5 Special work within the scope of usage of machine/plant and maintenance activities and also repairs during working, disposal .....	33 + 34
<b>11. Availability</b> .....	<b>18</b>	23.6 Instructions regarding special types of dangers .....	34
<b>12. Explosion drawing</b> .....	<b>19</b>	23.6.1 Electrical energy .....	34
12.1 Axial fan .....	19	23.6.2 Gas, dust, steam, smoke .....	34
12.2 Radial Ventilator design 1 (directly driven) .....	20	23.6.3 Hydraulics, pneumatics .....	34
12.3 Radial Ventilator design 2 (Drive via V-belt) .....	21	23.6.4 Noise .....	34
12.4 Radial Ventilator design 5 (Drive through coupling) .....	22	23.6.5 Oil, grease and other chemical substances .....	34
		23.7 Portable machines .....	34

Fig. 1:

Commonly used designs of the Axial fans		Commonly used designs of the centrifugal Fans	
A/G	 <p><b>Long casing</b> Flange motor Guide vanes Terminal box Service access (G=without Service access)</p>	1	 <p>Direct drive Impeller Access from Inlet side</p>
B	 <p><b>Long casing</b> Large door Flange motor Guide vanes Terminal box</p>	2	 <p>Belt drive with the base frame. Impeller access from inlet side. Motor mounted on rails Belt protection</p>
D	 <p><b>Short casing</b> Flange motor Guide vanes Terminal box</p>	2b	 <p>Belt drive Impeller access from Inlet side Motor mounted on the Rails on the bearing support.</p>
DD	 <p><b>Casing with bell mouth</b> Flange motor Guide vanes Terminal box</p>	5	 <p>Driving through coupling Impeller access from inlet side Common support for bearings and motor Safety guard.</p>
GD(R)	 <p><b>Long casing</b> With bell mouth ( R ) = fully reversible With bell mouth At both ends</p>	5S	 <p>Drive through coupling Impeller access from inlet side Common support for Bearings and motor Safety guard.</p>
Double inlet Belt drive on base frame Rotor to be dismantled from both the sides Shaft supported with two bearings Motor mounted on rails Belt protection	2/2		

## PREFACE

This is an operating and maintenance manual, not a system design guideline. During installation of fans a large number of factors that arise beyond the limitations of this manual must be taken into consideration. We must refer to the relevant standards, guidelines, standard sheets, specifications, EU-Directives, technical literature and courses that are offered by universities and associations such as AMCA, BS, VDE, VDI and VDMA among others.

Additional measures must be taken with the help of regional or legal specifications, standards, guidelines or rules.

The complete operating and maintenance manual as well as the technical data sheet for the fan must always be kept safe in the vicinity of the fan. Before operating the fan, the operating manual must be read carefully and understood. For doubts if any, please contact our company. We are not liable for damages resulting from non-conformance to this operating and maintenance manual. The fan is exclusively for the application described in the technical data sheet. Unless otherwise stated on the data sheet, the fan may only move clean air, it may only be installed in dry rooms (in clean air) and the inlet air temperature must be between 0 and 45 ° C. The fan requires an undisturbed inflow and outflow and no vibrations may be transferred to the fan via the foundation or the system. The installed motor must not be operated with a frequency converter. Any use outside the specified area of application is not in accordance with the regulations and can prove to be hazardous. Modification or changes are not allowed without clear written permission from us.

Using the state of art technology, with utmost care we have manufactured a solid and reliable fan just for you. However during operation, fans are often exposed to large-often unexpected-stresses. Improbable accidents must be avoided even in the event of simultaneous occurrence of multiple defects in the fan. In order to avoid damages and accidents fans must be regularly inspected and serviced by qualified technicians. Damaged bearing and high vibration levels in particular can lead to breakdowns and subsequential damage.

Despite high safety standards and their normally long service life every bearing finally wears out. Since minor damages, e.g in the conveyor belts, may quickly worsen, a regular inspection must be carried out giving the operating conditions due consideration. Destroyed bearings can lead to shaft failures and a total loss of the fan. Also V-belt drives and couplings are equipped with wearable parts and must be regularly inspected.

Vibrations prove to be harmful for all the rotating machines, since they can give rise to unexpected vibrational failures. Minimising the vibration energy is the best way of protection. At the time of delivery from our factory the fan has a high vibration quality. But due to bad inlet conditions, material build-up, wear, damages during transportation, fitting faults, bearing damage, over heating and other reasons, heavy vibrations can occur. Therefore along with the inspection of the bearings the vibrational quality must be checked regularly.

Fans should not be installed close to the working- and common areas. The fan must always be installed in such a way that no rotating parts can be touched. In case of free inlets or outlets protecting guards must be fitted. If ducts are connected to the fan, these must be provided on site with protecting guards. Parts that get separated from the impeller and contaminants must be securely retained by this.

Before starting any work on the fan, the electrical connections must be disconnected. The switching device must be marked and secured to avoid any unintended operation. The impeller must be mechanically blocked.

For work places close to the fan , if necessary, as per the occupational and environmental protection act, appropriate noise barrier measures for reducing the noise must be undertaken by the operator.

**We refer to the "Fundamental Safety Instructions" of WITT GROUP, which are an integral part of this Operating and Maintenance manual and must be strictly adhered to ( see sect. 23).**

**The EN ISO 12100 „Safety of machines” is the basis of all safety aspects.**

Important and relevant standards for fans:

Fan performance: EN ISO 5801:2017 / DIN EN ISO 13350:2015 / ISO 13347

Fan tolerances: ISO 13348

Process tolerances: DIN EN ISO 13920

Quality management: DIN EN ISO 9000/9001

**Please carefully follow the instructions given below.**

## COPYRIGHT

The copyright for this operating manual is held by the companies of the WITT GROUP and is exclusively intended for the operator of the fan. It includes technical directives and drawings that are to be neither completely nor partially distributed, duplicated or passed on to a third party without the consent of a company of the WITT GROUP.

### 1. TRANSPORT Please refer chapter 6.

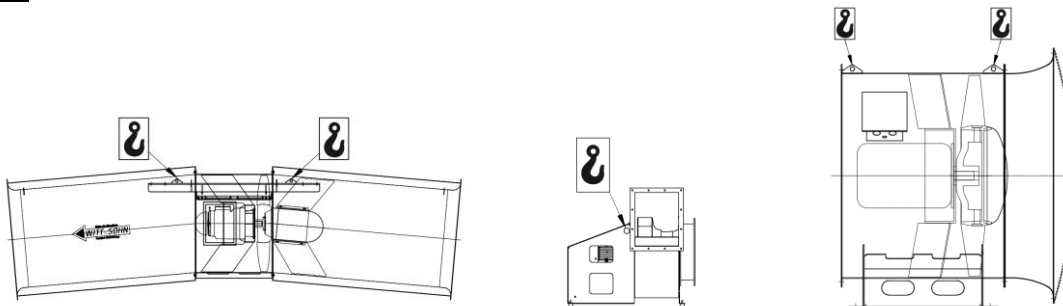
For lifting with cranes, attach hooks only to the marked lifting eyes provided for this purpose. Complete fans should be lifted only by using these lifting eyes, not by using lifting eyes of single components such as the casing or motor. While using fork-lifts, the fork is to be applied only under the base frame. Lowering shall be done at the lowest possible speed onto a soft support. Shocks, shaking and dropping might lead to imbalances and deformations or even damage in particular to the bearings.

For every transport and each storage it must be ensured that no water (e.g. by rain) can get into the motor, the bearings or other sensitive components. During short open transports and temporary storage in the open, axial fans (including jet fans) must be stored in a horizontal position, if possible under a canvas cover so that no water can penetrate along the shaft into the motor. We recommend only closed transport and storage in closed rooms without large temperature variations. While using fork-lifts for transportation all the mobile construction- or installation parts shall neither be touched nor damaged. The lowering must be done with the lowest possible speed. Shocks, shaking and dropping might lead to deformations.

Safety advice: Inspect secure connection between fan and hoisting device, pay attention to the centre of gravity, do not cant or tilt, do not step under the load!

### TRANSPORT-ADVICE

**Fig. 2:**



**Use only marked lifting eyes in case of lifting the complete fan!  
Do not use hoist askew, use a traverse beam to achieve vertical loads. Lift and lower load slowly, use a soft support!**

## 2. DELIVERY / INSTALLATION OF AXIAL- AND CENTRIFUGAL- FANS - GENERAL

While delivering the fan please check for external damages and immediately notify the transport company in case you have any complaints. (Or else insurance coverage, if any, may be invalidated).

When installing fans the instructions according to DIN 4024 (machine foundations) parts 1 and 2 must be observed.

Fans are to be installed only in the mounting position for which they were ordered and supplied (horizontal/vertical). Equipment must be installed on a level foundation. Care must be taken that the fans are not mechanically deformed or subject to unwanted forces in order to prevent jamming or grinding of the impeller.

While using vibration dampers, they must be placed such that a uniform load (deflection) is obtained, and it may be necessary to insert shims. When the fans are installed the damper must not be canted, dragged over the floor or stressed on one side only; this could damage the rubber or the springs.

Flexible connections must be installed in such a way that they allow the fan to have free movement especially during the start-up. On the other hand they should not be too compressed or misaligned that they form folds that could impede the air flow. **see also 15 Flexible connections.** In case of high pressure and danger of abrasion, guide rings (ducts) must be provided.

The fan must be connected to the motor according to the connection diagram in the terminal box and according to the instructions of the manufacturer. All motors are to be protected with the help of motor protection devices. Only a licensed expert staff must undertake the work of connections in conformance with the protection and safety instructions. (Also refer chapter 13. Electric motors)

Before commissioning, all the sensors and inspection devices must be connected and it must be ensured that the fan is disconnected during a given signal. In the construction planning and during the connection it must be ensured that a functional disturbance or cable disruption of a sensor is identified through a plant control and is interpreted as an alarm if required.

During the commissioning and the trial run, all the executed controls and tasks must be recorded.

## 3. INSTALLATION INSTRUCTION ACCORDING TO EC COUNCIL DIRECTIVE ON MACHINERY 2006/42/EC

### General requirement for all assembly and disassembly

- The work will be carried out only by trained specialist personnel, under the supervision of a qualified foreman.
- The customer safety and health protection requirements are known and respected.
- The installation personnel wear's the required protective or safety clothing.
- The complete operating and maintenance instructions have been read and completely understood by the trained personnel and the supervisor.
- All necessary work plans, construction drawings, technical data sheets were requested before installation and are completely available before work begins.
- All tools and equipment required to carry out the installation job (lifts, stages, lighting, etc. are available)
- All permits and approvals that may be required have been issued or are available.
- The responsible electrical specialist on site organises current free and voltage free system before any works begin. This includes the appropriate protection against any unintentional restart.
- After completion of work, the electrical specialist is responsible for the correct electrical setup.
- The attached commissioning report (Chapter 22.1) is carefully completed and returned to us for inspection, the required measuring equipment/ instruments are available and can be correctly operated.

### Transport of the machine to site

- Only approved transport routes may be used (maximum permissible roof-/crane-/floor-loads must not be exceeded, etc.)
- Only suitable and approved transport and lifting equipment shall be used for the set up of the machine. All current guidelines and standards are to be respected (max. loads, correct use of chains, etc.)
- Only the lifting points and eyebolts specified by us are allowed to be used- see section 1 (transport)

### (Re-)Assembly of the machine at site

- Under certain circumstances large fans must be dismantled into separate components to enable access through narrow access doors.
- Pages 18-21 show an exploded view of standard fans in order to facilitate dismantling - refitting.
- The pulleys must be in alignment, the tension of the belt must be properly adjusted. Very high tension can cause damage to the bearing and very low tension might cause belt wear, refer chapter 5.3
- In case of divided casings the casing parts must be joined using a log-life elastic sealing. The connecting corners between the separation flange of the casing and inlet nozzle are particularly critical.
- In case of flexible couplings, both the parts of the shaft must be aligned, see table on page 27.
- Starting couplings can normally be removed from the motor shaft ends and refitted in the same way as impellers. But in case of fluid couplings, we recommend the assistance of special expert staff.

### Special instructions for the (Re-)Assembly fo the machine at site

- All the parts fitting together must be marked before being dismantled. Special attention must be paid to the allocation of parts. Parts if interchanged may cause difficulties in installation. The impeller can be installed and dismantled either by the use of an extraction disc or a clamping bush (refer chapter 8 and 9).
- **Caution:** Under no circumstances should one dismantle the hub from the impeller backplate as this would definitely lead to an imbalance. The bearings must not be canted. Shims already used must be re-used after alignment. The bearing casing and foundation must be carefully bolted. During the remounting of the impeller on the shaft, the use of graphite based grease can be advantageous.
- **Caution: Taper-lock bushes should not be greased!**

- **Single inlet centrifugal fans.** For fans with undivided casing in which the impeller can be dismantled at the motor side, after disconnecting the motor only the disc is unscrewed and the screws at the pedestal are loosened. The impeller can be taken out of the casing the motor can be dismantled from the base: Mounting of the impeller is described in the chapter 8 and 9. Then the motor and the bearing with the shaft are removed at the drive side.
- **For split casing:** Screws at the inlet nozzle have to be released and these are to be removed from the casing. The upper part of the casing is lifted off after removing the flange screws. The impeller has to be supported by wooden wedges or lifted by a crane using fastening slings, but is not to be lifted yet. Remove the fastening screws of the motor and bearing casing. Loosen the extraction disc and also the taper-lock-bush and pull the shaft with bearing out of the hub of the impeller using an extraction device. Subsequently the impeller can be lifted out of the lower part of the fan casing.
- **Double inlet centrifugal fans:** In case of single casing the impeller has to be supported inside the casing (wooden wedges under the front plate of the impeller, not under the impeller blades) so that the bearings are relieved. Then the screws at the foot of the bearing casing are removed and protection grill, inlet bellmouth and bearing support at the opposite side of the drive are taken off. Now the impeller with the shaft and bearing casings can be horizontally drawn out. If required the casings of the bearing are dismantled and the bearings are drawn off.
- **In case of split casing:** Remove screws of protection grill and inlet bellmouth, take off the belt drive, and take off the upper part of the casing after removing the flange screws. Fasten the impeller at the crane by means of fixing devices, but do not yet lift. Remove fixing screws from the bearings of the casing. Fix lifting devices at both the ends of the shaft and connect to the crane. Carefully hoist the complete unit of impeller, shaft, bearing, inlet bellmouth out of the lower part of the casing. Further dismantling of the parts can be done after setting down the complete unit.
- **Axial fans:** Fans with split casings must be differentiated from all other designs. The upper part can be lifted off. The impeller can then be detached either with an extraction disc or taper lock bush. (refer chapter 8 and 9) The motor bolts can then be removed. Caution – Use lifting devices.

#### **Mechanical installation of the machine at site**

- The work will be carried out only by trained specialist personnel, under the supervision of a qualified foreman.
- The available space at the installation site must be checked before start of activities - does the fan fit into the intended place?
- To ensure a safe installation, the machine is fixed with the provided attachment points on the system. On the one hand this are the flange connections which have to be made with the previewed bolts. On the other hand a fixation at the ground is required. For the exact positioning of the fastening the technical requirements at the drawings, data sheets (dimensions, spacing, etc.) must be taken into account; and always before fixing the machine an authorization by the responsible site manager to required (is the position of dowels / screws chosen allowed, have requirements as in example maximum setting depths been respected, is the selected mounting base suitable for the load, etc.). Only if such an authorization was granted the fixation work may be started.
- To ensure a safe installation, the machine is fixed with the provided fixings points. This are flange connections, pre-drilled for bolt connections and fan fixation to the ground. For the exact fixing positioning, please refer to the technical requirements shown on the drawings, data sheets (dimensions, spacing, etc.) These details must always be taken into account before fixing the machine and final authorisation by the responsible site manager is required (correct positioning, correct fixings and requirements such as maximum setting depths, is the selected mounting base suitable for the load, etc.). Only if such an authorisation is granted the fixation work can begin.
- If vibration attenuators are used it has to be checked that all attenuators are uniformly compressed by the weight of the machine (at standstill and also in operation) to achieve optimum insulation. If this is not the case, the differences in height have to be compensated, or the dampers have to be repositioned after technical clarification with us.
- If the fan connection to the ventilation system is done with flexible connections., it has to be ensured that the flexible connections are not:
  - Compressed too much, as this may lead to an extreme disturbance of the air flow (up to a stall phenomenon which destroys the entire machine!)
  - Stretched too much, as this may lead to damage of the flexible connections within a short time period.
- If no mechanical protection equipment was ordered with the machine (protection grills or similar), the necessary protection must be planned and installed by the responsible system builder. Without this mechanical protection the operation of the machine is not permitted and is prohibited!

#### **Electrical installation of the machine**

- The electrical work must be carried out only by trained specialists only.
- Respecting all relevant and valid regulations the machine is connected to the electrical supply and monitoring network. For further details please refer to section 13 (electric motors) of this manual.
- The required electrical protection system and (emergency) breakers must be planned and installed by the responsible system builder. Without this electrical protection the operation of the machine is not permitted and is prohibited!

#### **Commissioning of the machine**

- The commissioning is described in detail in section 4 (Commissioning) of this manual.
- If the machine was stored for a longer time period before installation the additional information of section 6.3 (Start-up after long term storage) has to be respected and implemented.
- In chapter 10 of this manual you will find additional instructions and help for all kind of special applications as hot gas, smoke extraction, ATEX, operation with frequency converter/soft starter etc.

## 4. COMMISSIONING

#### **General safety instructions:**

Before commissioning the fan, the casing and the duct pipes must be checked for contaminants. Loose parts can be carried away by the air flow and can lead to injuries. Care must be taken when installing the protection grills, belt protection and other safety features. No one should ever stand in the way of the air flow! The air pressure might be so strong that a human body and even heavy objects could be sucked into the fan or blown away. (Also refer chapter 22 installation and maintenance report)

The safety instructions for electrical equipment and of the electricity supply company must be observed at all times.

The rotational direction of the fan is indicated by an arrow on the fan casing, fan protection or motor. This should be checked by briefly starting the motor and observing the rotating parts. If it is wrong, the electrical leads must be reconnected. The amperage must be measured and compared with the nominal current of the motor. Centrifugal fans must be throttled appropriately; otherwise the motor can be overloaded. The reverse is true for axial fans. With free outlet they absorb less power than when throttled.

Before the rotation direction is reversed, the impeller must come to a complete standstill. The high moment of inertia can otherwise lead to damage.

#### 4.1 Mechanical safety

To prevent any contact between moving parts, safety devices must be installed. If they are not supplied as an integral part of the fan, they must be installed on site. This especially is applicable for inlets, outlets and access doors which must be secured on site.

#### 4.2 Fans with belt drive

The belts must be checked (also refer chapter 5.3) to ensure they run smoothly. The bearing temperature must be monitored. The temperature on the bearing housing will normally rise to 50-60°C (warm to the touch), rarely to 70°C or more. Be careful while touching! If the temperature rises to higher values, the system must be restarted after a cooling down period and subsequently the probable cause for the fault must be found and eliminated. The belts are to be tightly tied. It must be verified that the bearings are good but not excessively lubricated.

#### 4.3 Systems with dampers

Dampers that can interrupt the airflow completely must be connected in such a manner that the fan is automatically stopped immediately after closing the damper. Otherwise an excessive heating of the fan and excessive vibrations can occur.

#### 4.4 Fans operating in parallel

When multiple fans are connected in parallel ensure that the non-operating fans are not rotating in the direction opposite to their intended rotational direction. Starting the fan rotating in the wrong direction can otherwise lead to overload of the power supply and motor and cause damages to the blades. Fans must be ordered for parallel installation. Attention while carrying out maintenance activities: The impeller has to be mechanically blocked before starting any of the activities at the fan.

#### 4.5 Stall / anti-stall device

The operation of fans at stall condition is forbidden. If the fans were equipped with an anti-stall device the vibrations on the blades at stall conditions are minimised so that in emergency or run-up/down conditions the stall region of the fan curve can be passed without any problem. Also with anti-stall device continuous operation at stall is forbidden.

#### 4.6 Maximum speed, different speeds and speed control

**The fan should not be operated at higher speeds than those stated in the data sheet.** A speed reduction is permissible only in consultation with the WITT GROUP. It must be ensured by measurements that the fan is not operated at a frequency, where a resonance frequency is excited in harmful quantities. As resonance frequencies are strongly affected by the fan installation (foundation, connection to the duct system etc.) and also by aerodynamics in the system, an accurate prediction of the resonance frequencies is not possible at the manufacturer premises. Possibly supplied so-called "run-down-curves" are only an indication of more or less pronounced resonance frequencies for the isolated fan. When using speed control you have to expect that resonance frequencies are exited from minimum to maximum speed. **At these corresponding speeds no permanent operation of the fan / system may occur.** When commissioning the entire system the variable speed control must be programmed so that these resonance speeds are quickly bypassed. Please refer to chapter 10.3.

#### 4.7 Motor protection switch

Fans have a relatively high moment of inertia. In most cases for heavy start relays are necessary. While selecting and setting the relays the whole operating range must be considered. For example a fan motor will draw 16% more current when the feed medium going through the fan is at -20° C than at 20° C because of higher atmospheric density.

#### 4.8 Starting couplings

To avoid excessive heating and overloading of the coupling, a maximum of only 4 starts per hour is permissible. Between any 2 starts a cooling period of at least 10 minutes is required.

#### 4.9 Explosion-proof fans (also refer 10.6 Ex-protection)

Very special care must be taken. In addition to other instructions the following must be noted.: **The build-up of electrostatic charges must be avoided by grounding all relevant parts. Special care must be taken to ensure that there is adequate distance between rotating and non-rotating parts and the motors at no point become overloaded or overheated.**

#### 4.10 Torque figures of bolts

Torque figure in Nm (not binding value)							
Screw quality	8,8 (zink plated / lamellar zink coated / hot dip galvanized)	4,6 (welded-stud)	A2/A4/A5 – 50 (turned)	A2/A4/A5 – 70 (rolled)	A2/A4/A5 – 80 (cold formed)	1.4529 (turned)	
friction coefficient	~ 0,14 / ~ 0,12 / ~ 0,16 (non greased) Tightened washers must have minimum hardness class 200 HV (see DIN EN ISO 7090, 7093 or 6340)	~ 0,14 (non greased)	~ 0,16 Use Anit-Seize Assembly paste ! (thread only)	~ 0,16 Use Anit-Seize Assembly paste ! (thread only)	~ 0,16 Use Anit-Seize Assembly paste ! (thread only)	~ 0,16 Use Anit-Seize Assembly paste ! (thread only)	
Thread size	M4	3,3	1,2	1,1	2,4	3,3	1,5
	M5	6,5	2,4	2,3	4,9	6,5	2,9
	M6	11,3	4,1	3,9	8,4	11,3	5,2
	M8	27,3	10,1	9,6	20,6	27,4	12,5
	M10	54	20,3	18,0	40,7	54,3	24,6
	M12	93	34,0	32,9	70,5	93,9	42,4
	M14	148	55	52,4	112	150	68
	M16	230	85	81,4	174	233	108
	M18	329	118	113	242	322	150
	M20	464	167	160	342	456	212
	M22	634	225	219	470	-	289
	M24	798	287	275	589	-	364
	M27	1176	424	408	873	-	-
	M30	1597	575	553	1186	-	-
	M33	2161	780	751	-	-	-
M36	2778	1002	964	-	-	-	
M39	3597	1299	1250	-	-	-	

Attention: Subsequent control just with 80 % of the above-mentioned values

Tightening torque for electrical terminal boards (values) in Nm:		
bolts		tightening torque in Nm
thread d	material	
M 4	CuZn37 F45	1,2
M 5		2
M 6		3
M 8		6
M 10		10
M 12		15,5
M 16	CuZn37 F38	30
M 20		52
M 10	E - Cu57 F25 oder E - Cu58 F25	10
M 12		15,5
M 16		30
M 20		52
M 24 x 2		80
M 30 x 2		150
M 33 x 2		197
M 36 x 2	252	

## 5. MAINTENANCE

The safety instructions given under the sections "preface" and "commissioning" are valid for re-commissioning after maintenance activities. The frequency of maintenance depends largely on the operating conditions, environmental conditions and the required availability. The frequency must be set by the operator taking into consideration the plant layout and in compliance with the specifications given by us. Sufficient spare parts must be provided. A standard interval is for maximum of 6 months (also refer chapter 22 installation and maintenance report). Attention: Fans for Ex zones must be revised by us or an authorized service company at least every 3 years (or after 20,000 operating hours - whatever occurs first).

All impellers have been carefully balanced at the factory premises itself. Imbalance can occur due to dust, wear, abrasion and accumulation of material on the impeller leading to vibrations and damage of bearings. Therefore an operation free of vibrations must be ensured.

### 5.1 Surface protection

The surface protection of a component too must be regularly checked and if required maintained. Especially mechanical damage to the surface due to rockfall, dust or chemical impact must be looked out for. Even stainless steel can be subject to surface corrosion, e.g when it is subjected to a very moist salty environment or aggressive gases.

Therefore it must be ensured that surface corrosion does not affect the general properties of the fan and does not present a situation where maintenance activities are urgently required, but can be rectified and improved just by carrying out suitable maintenance tasks within the period of warranty. Corrosion can be prevented typically by cleaning the surface and by using a suitable surface conservation technique.

### 5.2 Monitoring vibrations

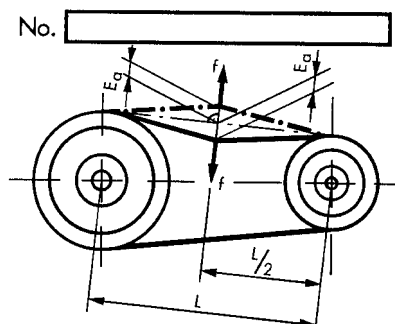
Increased vibrations are always a danger (ISO 14694:2003 or ISO 10816-3:2018). Changes in the vibration level can be monitored by measuring the mechanical vibrations on the bearings and motors. Variations can be detected by comparing the measured values over a prolonged period of time. If significant changes occur (increase > 30% compared with the values one year before) are observed the cause must be examined, e.g. dirt accumulation on the impeller. The necessary procedures to avoid the problem (e.g. cleaning and/or rebalancing of the impeller) have to be taken.

### 5.3 V-Belt drive

Belts will be stretched in the course of time, especially during the initial operating phase. Therefore regular checks and re-tightening of the belts are necessary. The values given in the table below as well as those in the separate documentation must be observed. Very high tension increases the bearing load (risk of damage to the bearings), while a very low tension leads to belt slip, and a very low tension leads to belt slip, creaking and additional wear. Re-tightening is possible by parallel shifting of the motor in its rails or lifting the motor pivot. Care has to be taken to see that the pulleys remain strictly parallel to each other (use a ruler or a piece of string). The correct belt tension can be determined by measuring the deflection  $E_a$  using a spring balance.

If belts are to be replaced it should always be done intermittently (equal length). Replacing a single belt is strictly not permitted. New belts must be fitted with extreme care to avoid overstretching. For new belts the initial tension should be set higher, so that the deflection measures 0.75 x the tabular value. For re-tightening, the tabular value or the value from the special documentation should be used.

Fig. 3:



No.

Impression depth per belt  $E_a$  in mm  
 Test force per belt  $f$  in N  
 Centric distance  $L$  in mm

We recommend the following **intervals for re-stretching**:

1. Check: 2 to 3 hours after start-up,
  2. Check: 8 to 12 hours after start-up,
  3. Check: 1 week after start-up,
- Further checks according to requirements and operating conditions

#### Pretension for V-belts

The centric distance  $L$  between the pulleys is measured and a defined force  $f$  (see table) is applied at the middle of the belts. Then the deflection  $E_a$  is measured and the tension is adjusted until the  $E_a$  value from the table is reached.

#### Example:

A belt drive has 180 Ø as the smallest pulley diameter, a SPB profile and  $L = 1000$ mm.

For a force of 75 N/belt the deflection

$$\text{For re-tightening } E_a = \frac{3,32 \cdot 1000}{100} = 33,2 \text{ mm}$$

For the initial set up with new belts  $E_a$  should be  $E_a = 0,75 \times 33,2 = 24,9$  mm.

Fig. 4:

Profile	Test force f per V-belt f (N)	Diameter of the smallest pulley (d <sub>k</sub> mm)	Deflection depth E <sub>a</sub> Per 10mm center distance E <sub>a</sub> (mm) Standard
SPZ	25	56 ≤ 71	3,19
		> 71 ≤ 90	2,86
		> 90 ≤ 125	2,67
		> 125	2,47
SPA	50	71 ≤ 100	4,16
		> 100 ≤ 140	3,58
		> 140 ≤ 200	3,33
		> 200	3,19
SPB	75	112 ≤ 160	3,90
		> 160 ≤ 224	3,32
		> 224 ≤ 355	2,89
		> 355	2,73

**Belt tension for standard V-belt types**

**In case of other types, e.g larger drives, see separate documentation (Label)**

#### 5.4 Flat belt drives

The flat belt tension is adjusted at our work premises and normally needs no re-tightening or maintenance. When a new belt is installed, it is important to stretch it exactly as instructed. Very high tension increases the bearing load (risk of bearing damage), and a very low tension leads to belt slip, creaking and additional wear. Please follow the special instructions for flat belt by the manufacturer.

The correct stretching is obtained as follows: Put the belt on a plane surface and mark two points e.g spaced exactly 1000mm apart. Mount the belt on the pulleys and stretch it by gradually shifting the motor on its rails. The correct elongation is achieved when the distance between the reference marks increases by the nominal value. In order to stretch the belt evenly the belt drive has to be turned manually several times.

Example: Stretching 2%, Distance before tensioning = 1000 mm, Distance afterwards = 1020 mm

#### 5.5 Bearings

For maintenance of the motor which is installed inside the fan please refer primarily to the motor manufacturer's own instructions attached separately. All following information and instructions concerning the motor bearings are subordinate and supplemental.

##### 5.5.1 Monitoring of bearings

Every bearing has to be checked regularly. Dirt particles, contaminants and moisture must not enter the bearing as they may cause premature failure. While relubricating or replacing bearings, utmost cleanliness must be observed.

While monitoring bearings it is a great advantage to use electronic shock pulse measurement (e.g SPM-method). Measure should be made directly at the bearing unit. The special instructions of the test equipment manufacturer must be adhered to. Not only the momentary values but also the comparison of the data over a prolonged period is important since this best allows the changes in the bearing to become apparent. In rare cases SPM-measurements can lead to wrong interpretations. Bearing noise and temperature too should be recorded especially for machines that are critical. Increase in values are always a sign of danger.

The relubrication intervals are valid for stationary machines under normal conditions for non-ageing lithium soap lubricants as per section 5.5.4, as long as the temperature on the external bearing ring remains below +70°C. For higher temperatures every increase by 15°C the greasing interval is halved. The maximum temperature limit of the grease is not to be exceeded.

The life expectancy of bearings is largely dependent on the operating conditions and the conditions at the site of installation. We strongly recommend regular bearing checks. The frequency depends on the importance of the fan. For every fan the user should make a risk analysis. This will sometimes have the result, that for very important machines, an annual bearing replacement may be economically worthwhile, even if running times and vibration levels are low, in order to practically exclude the remaining statistical risk of a bearing failure. Bearings for less important machines should be replaced less often or when a breakdown is imminent.

## 5.5.2 Additional instructions for various fan bearing types

The types of grease to be used and applicable re-lubricating intervals are specified in 5.5.3. Necessary re-lubrication should if possible be done while the machine is running with necessary safety precautions. If this is not possible, turn the shaft by hand. It is important that the inside of the bearings remain absolutely clean from moisture, dirt and dust. Bearings that located in the path of the air flow are provided with double-lip seals. High performance grease as mentioned in 5.5.3 must be used. At our factory all the bearings are lubricated with a heavy duty long life grease. The lubricant must be changed only after the completion of the long life of the lubricant.

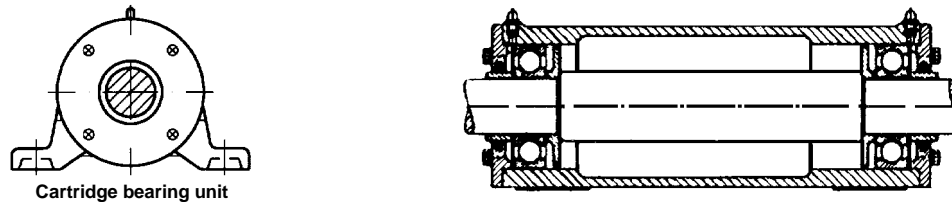
- **Bearings with permanent lubrication**

Bearing with permanent lubrication, recognized by the absence of grease nipples, do not need re-greasing.

- **Cartridge bearing with re-greasing device and grease control disc**

Regreasable bearings need to be refilled after the first hour of operation with grease (3 times the amount of grease indicated on the lubrication plate). After the first 24 hours of operation, the bearings must be refilled once again (1 times the amount of grease indicated on the lubrication plate). During relubrication the control discs remove old grease and press it out through the openings into the bearing casing. During relubrication the temperature may temporarily rise due to the presence of too much grease. The temperature will fall to its normal steady state level once the excess grease is ejected by the control disc. The grease can be removed after prolonged periods e.g at the time of replacement of bearings.

Fig. 5:



Cartridge bearing unit

- **Pedestal block bearing with re-greasing device and grease control disc**

Regreasable bearings need to be refilled after the first hour of operation with grease (3 times the amount of grease indicated on the lubrication plate). After the first 24 hours of operation, the bearings must be refilled once again (1 times the amount of grease indicated on the lubrication plate). During relubrication control discs remove old grease and press it out through the openings into the bearing casing. During relubrication the temperature may temporarily rise due to excess grease. The temperature falls to its normal steady state level once the excess grease is ejected by the control disc. The re-lubrication is best done by taking the necessary precautions to avoid coming in contact with mobile parts- especially for a running machine, so that the surplus old grease that comes out can be immediately removed and not be carried away by the air stream (for fans in which the bearing lies in the path of the air stream, such as axial fans and centrifugal fans with double inlets).

- **Pedestal block bearing with re-greasing device and without grease control disc (special version, only available on request)**

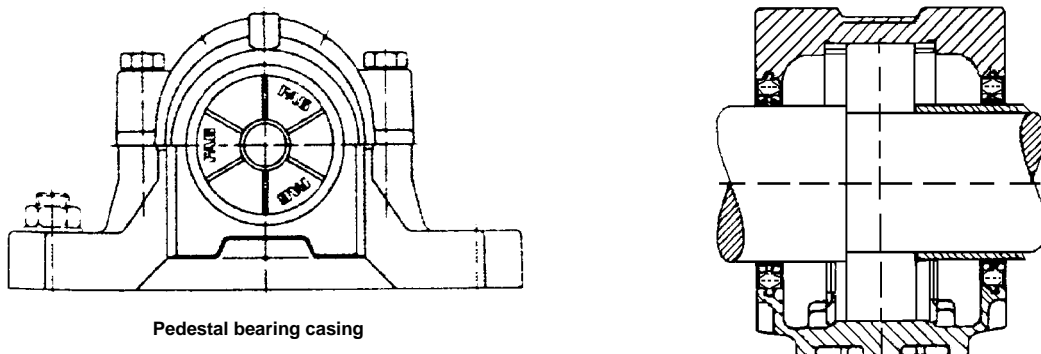
Initially upto 2/3<sup>rd</sup> of the bearing is filled with grease. Relubrication of smaller quantities must be done at specified intervals. The correct quantity of grease should be applied, because overgreasing may lead to an increase in temperature. The installed overpressure valve helps in compensating the pressure between the internal area and the atmosphere. After several relubrications if the casing is filled with grease, then the grease must be changed.

For this the upper part of the housing is taken off and the old grease is removed without damaging the bearing. New grease has to be squeezed by hand into the bearing. Please use clean grease and take care that no impurities come into the grease.

- **Pedestal block bearing with permanent lubrication (without grease nipple)**

For this the upper part of the housing is taken off and the old grease is removed without damaging the bearing. New grease is squeezed carefully by hand into the bearing. Please use clean grease and take care that no impurities come into the grease. The space between the lip seals too must be filled with grease so that the friction between the lips and shaft are reduced.

Fig. 6:



Pedestal bearing casing

## 5.5.3 Additional notes motor bearings / pillow block bearings

In addition and subordinated to the instructions of the motor supplier we would like to draw your attention particularly to the following points:

### Impact of operating time to bearing service lifetime

If fans are operated less than 100 h/year there is a high risk that the grease used in the bearings loses prematurely its function (separation of oil and solids) and this could lead to total failure at any time. In order to avoid this a so called maintenance-operation is essential: The motor bearings / pillow block bearings are brought up to operating temperature every 3 months. The easiest way to achieve this is a 1,5-hour operation ('maintenance-operation') at full speed. According to motor makers advice motor bearings / pillow block bearings should be relubricated every 2 years and – if necessary - even be revised.

With normal operation (100 h/year to about 5000 h/year) we recommend that at least every 10 years the bearings are revised.

With more than 5000 h/year in most cases the lifetime of the bearings is achieved after 5-7 years and a precautionary exchange of the bearings is recommended.

### Smoke extract fans , certified to DIN EN 12101-3:2015

Warning: Smoke extract fans are subject to the provisions of Regulation EU No. 305/2011 and the operator is required to fulfill the " essential characteristics " of the EU BauPVO over the entire lifetime of the fans. That means that all changes/retrofits to the smoke extract fans are only allowed to be executed by specialised companies or the fan manufacturer. Both companies must be certified and inspected annually. The inspection must be made by a certified authority in accordance with EU Directive . If one of the characteristics of the smoke extract fans, underlying the certification process is changed (different motor bearing, different grease, modified impeller clearance etc.), the CE marking for the fire rating must be removed.

## 5.5.4 Grease quality, quantity and lubrication intervals

The lubrication intervals for all fan roller bearings can be found on the corresponding sticker attached to the fan, on the respective separate lubrication labels on the individual components (e.g. motor bearings, block bearings, ...) or in the documentation sent with the fan.

In most cases known to us, the first relubrication interval is reached after years. To prevent severely aged grease from being pressed into the bearings via optionally attached relubrication lines, these lines are NOT filled with grease on delivery!

*The correct procedure is described below using the example of "regreasable motor bearings". (This procedure can be transferred accordingly to other components with roller bearings.)*

When the first relubrication interval is reached, the following procedure is required:

- a) If the motor is relubricated directly, the fan is switched on and twice the amount of grease specified on the type plate is pressed into the bearings during operation. This eliminates the "residual air" in the engine's relubrication channels.
- b) If lubrication is carried out via optionally attached relubrication lines (the grease nipples are not located directly on the motor but on the fan housing), these relubrication lines must be filled with grease at first.

To do this, the relubrication lines on the motor are to be loosened and then filled with grease (see note 1). Then the relubrication lines are reattached to the motor and any grease openings at the motor have to be opened.

Then the fan is switched on and, during operation, the motor bearings are finally filled with twice the amount of grease specified on the type plate. This eliminates the "residual air" in the engine's relubrication channels.

From the second relubrication interval, relubrication is carried out during operation with the amount of grease specified on the type plate.

*Note 1: Approx. 20ml grease per meter of relubrication line is required to fill the empty relubrication line.*

*Note 2: If commissioning takes place more than a year after delivery, the motor bearings should be "flushed" with twice the amount of grease specified on the type plate.*

*Note 3: If the fan is not used over a long period of time (1 year) or generally only very rarely, the grease in the relubrication lines (and also in the motor bearings) can lose its viscosity. In addition to massively increased bearing wear, this can also lead to a significant increase in the required relubrication pressure (which also can lead to errors in automatic relubrication devices). In such a case, not only the relubrication lines on the motor have to be loosened and "flushed" with new grease, but also the motor bearings have to be "flushed" with twice the amount of grease specified on the type plate.*

## Oil lubrication

While using oil lubrication special instructions must be noted. At the factory necessary quantity of oil is filled into the casing. When re-starting after prolonged stoppages, the oil level must first be topped up to "max" again by refilling the oil. It is recommended to change the oil after a couple of hours after the initial commissioning.

All subsequent oil changes must be done at suitable time intervals (at least annually) depending on the operating conditions. The oil must be changed when the equipment is idle.

If during trial run no leakage of oil is observed, an occasional check of the oil level – for example once a month - is sufficient. During the operation the oil level may reach the "min" marking. When the system is running the quantity of oil added should be at least 5mm below the maximum marking to avoid excess oil being added besides the oil in circulation.

## 5.6 Shaft seals for gases and fluids (also refer chapter 10.2 gas-tight fans)

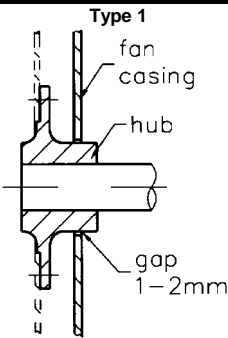
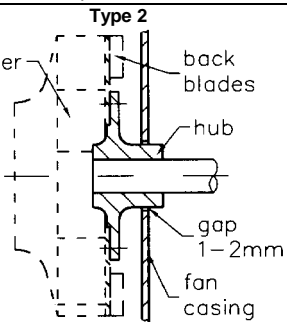
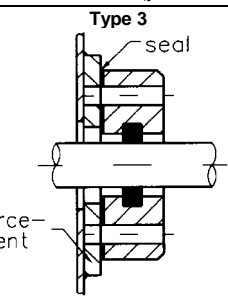
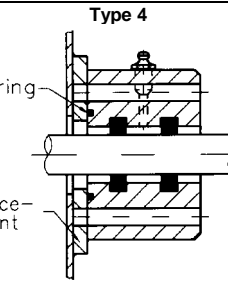
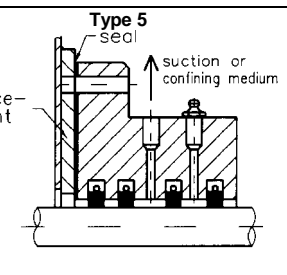
There are a number of different sealing methods (refer the image on the following page). The selected method must always be checked to see whether it is suitable for the toxicity of medium. A regular relubrication along with a leak test must be carried out since often the real operation conditions are not known. The test is carried out either with the use of gas detecting equipment, human nose or by pressure testing. For this, critical parts are sprayed with a lathering fluid to detect the leaks. Leakage points must be identified by the bubbles. The tightness of the entire pressurised fan casing too can be tested by measuring the drop in pressure after applying excess pressure in the interior of the casing.

We recommend a change of seal rings at least once a year.

The seals of type 3 and 4 must be lubricated regularly in order to avoid excessive wear and temperature rise. Type 5 is designed to operate without grease, but a grease filling considerably reduces the leakage (refer section 5.5.3). **While choosing the grease the operating temperature as well as compatibility with the feed medium must be considered!** The relubrication intervals depend on the operating conditions and must be empirically checked every 6 months. The grease chambers are then refilled slowly while the impeller rotates. The necessary amount of grease is filled when the resistance to the filling noticeably increases (use only manual lubrication presses!). Under no circumstances should the grease be pressed forcefully into the seals, because the sealing rings can be pressed apart. Additional greasing should be carried out only if the seal is leaking. If special oiling or cooling equipment has been installed then special instructions in the documentation must be adhered to. Seal gas must be used for solid media.

## SHAFT SEALS

Fig. 7:

 <p><b>Type 1</b> fan casing hub gap 1-2mm</p>	<p><b>Hub lining</b></p> <p>Standard design, gap between casing and hub about 1-2mm</p>	<p><b>Sealing class I</b></p> <p>No requirements</p>
 <p><b>Type 2</b> impeller back blades hub gap 1-2mm fan casing</p>	<p><b>Hub lining, impeller with fuming bars</b></p> <p>The negative pressure produced reduces the leakage rate.</p>	<p><b>Sealing class I</b></p> <p>No requirements</p>
 <p><b>Type 3</b> seal reinforcement</p>	<p><b>Modell WD1</b></p> <p>With one sealing ring. For increased requirements Can be combined with impeller fuming bars.</p>	<p><b>Sealing class II</b></p> <p>As per DIN EN 1507:2006; for test pressure 1000 Pa:</p> $\text{Leakage rate max: } 24 \cdot 10^{-3} \left[ \frac{\text{m}^3}{\text{s} \cdot \text{m}^2} \right]$ <p><math>\text{m}^2 = \text{inner surface of the fan casing}</math></p>
 <p><b>Type 4</b> O-ring reinforcement</p>	<p><b>Modell WD2</b></p> <p><b>A)</b> with 2 sealing rings and Lubrication chamber and Relubrication equipment with Grease overflow duct</p> <p>Can be combined with Impeller Fuming bars</p> <p><b>B) Grease filling is required</b></p>	<p><b>A) Sealing class III = Standard</b> As per DIN EN 1507:2006; for test pressure 1000 Pa:</p> $\text{Leakage rate max: } 0,8 \cdot 10^{-3} \left[ \frac{\text{m}^3}{\text{s} \cdot \text{m}^2} \right]$ <p><b>B) Sealing class IV</b> (Sealing type: WD2) <b>Nuclear standard</b> according to DIN 25 414:</p> $\text{Leakage rate max. } 10 \frac{\text{dm}^3(\text{bei } 1 \text{ bar} + 20^\circ\text{C})}{\text{h} \cdot \text{m}^2}$ <p>Test pressure <math>\Delta p = 20 \text{ mbar} = 2000 \text{ Pa}</math></p>
 <p><b>Type 5</b> seal reinforcement suction or confining medium</p>	<p><b>Modell WDK</b></p> <p>With two or more sealing rings, grease chamber and lubrication nipples. Vacuum suction or sealing gas is required for applications with special requirements for tightness, temperature and tip speed.</p> <p><b>For temperatures up to 500° C</b></p>	<p><b>A) Sealing class III without blocking medium</b> As per DIN EN 1507:2006; for test pressure 1000 Pa:</p> $\text{Leakage rate max: } 0,8 \cdot 10^{-3} \left[ \frac{\text{m}^3}{\text{s} \cdot \text{m}^2} \right]$ <p><b>B) Sealing class IV with inert gas:</b> As per DIN EN 1507:2006; for test pressure 1000 Pa:</p> $\text{Leakage rate max: } 0,27 \cdot 10^{-3} \left[ \frac{\text{m}^3}{\text{s} \cdot \text{m}^2} \right]$

**Casing materials for all designs: Standard mild steel**

**Sealing rings:**

**Standard:** FPM / FKM -30/+200°C, lubrication required  
Running speed  $v \leq 14 \text{ m/s}$

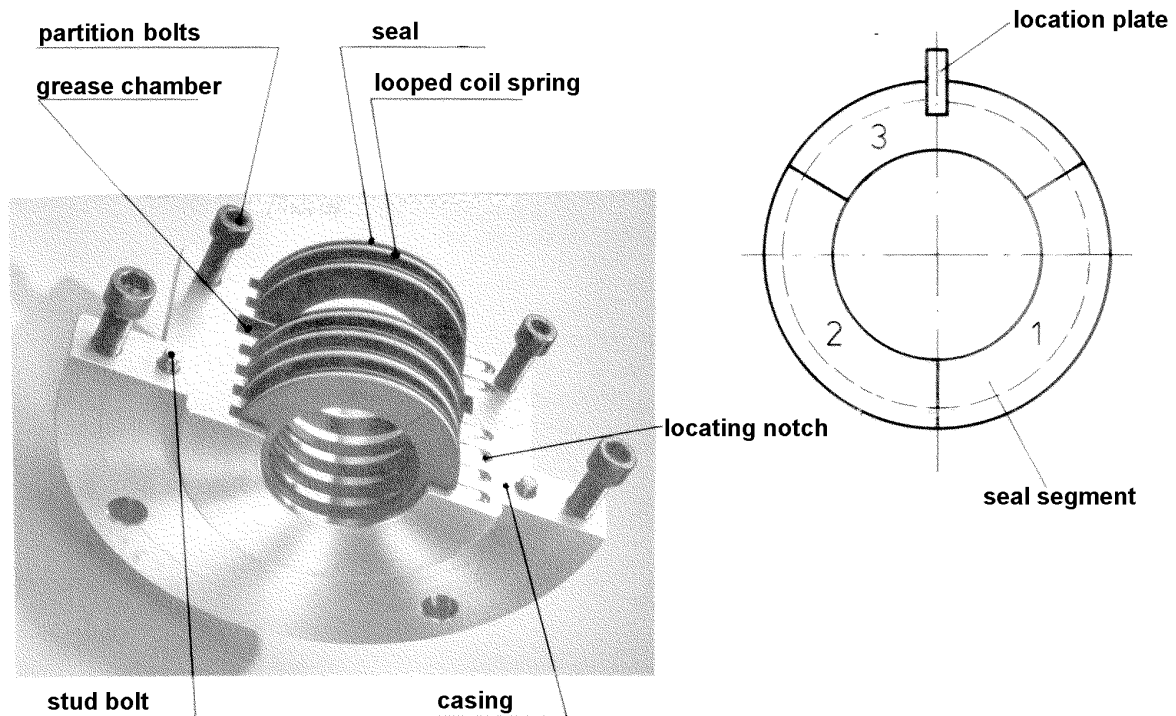
**Options:** Stainless steel, aluminium

**Options:** PTFE -80/+200°C, self lubricating.  
Running speed  $v \leq 18 \text{ m/s}$

## 5.6.1 Mounting the seals Model: WDK

Special care must be taken while assembling WDK-seals.

**Fig. 8:**



Carefully draw shaft sleeve with O-Ring over the shaft and insert flat or round sealing against the casing.

With the bore of the casing (with thread for partition bolts) under the shaft and fix with fastening screws so that the partition is almost horizontal.

Remove the looped coil spring from the first seal ring. Open the hooked spring lock and insert the spring from one end into the first chamber (seen from the pressure side) of the seal casing unit till one can grip it from the other side. Fix the locking plate on the spring and apply the spring lock.

Slightly grease sealing element 1 on both lateral sides, place with bore on the shaft and insert locked spring into the spring groove of the sealing ring. Align sealing ring segment 1 in axial direction to the first chamber and push it into the chamber. Slightly lubricate sealing ring segment 2 on both sides, place with bore onto the shaft and draw spring into spring groove. Push sealing segment 2 so far into the chamber until sealing ring of segment 1 appears on the other side. Slightly lubricate the sealing ring segment 3 (with locking groove) on both sides, place with bore onto the shaft and draw spring into spring groove. Ensure that the locking plates properly grip the securing groove on the sealing ring.

The individual sealing ring segments are marked with the same numbers and must enclose the shaft in the same arrangement. Turn assembled sealing ring on the shaft until the locking plate grips into the locking groove of the divided casing.

The other rings can be inserted in the same way as ring no.1 for which the sealing rings must be lubricated slightly on both the sides. After installing the last sealing ring align all exposed segments so that the second half of the casing can be easily placed on top. The correction position of the locking plate must be checked once again.

Slightly grease the second half of the casing in its partition and draw it carefully over the sealing rings and bolt it together with the lower part of the casing.

Detach the fastening below the shaft seal and turn shaft seal so far onto the shaft until the connection for the grease re-lubrication has reached the correct position.

Place flat or round sealing surface of the fan casing, align shaft sealing to shaft and screw onto the back side of the fan.

## 5.7 Mechanical starting couplings

The maintenance mostly depends on the operating conditions. Generally a continuous control is not necessary as the internal roller bearings are exposed to dynamic stress during the starting phase until the nominal speed is attained. The bearings are completely enclosed and do not have any re-lubricating devices. For heavier loads, e.g. due to frequent starts (more than four times a day), for temperatures above 50°C, and for the effect of dust, we recommend a check for the roller bearings, the sealing rings and the abrasion of the coupling after about 8000 hours of operation.

## 5.8 Impeller inspection / Material fatigue

For likely abrasion, corrosion or dirt deposits on the impeller regular inspections, cleaning and repeated balancing must be carried out at least once a year and in extreme cases it can be done even at intervals of one or two weeks. Wearing plates on the impellers should be installed only in the factory. Provision of a second impeller is recommended for alternate processing. The impeller must be changed not later than 100,000 start/stop procedures or after 100,000 operating hours due to probable material fatigue. Jet fans installed in railway tunnels must be checked regularly (every 6 months) for material fatigue, especially in the area of the suspension.

For fans with frequency converters the impellers must be regularly checked for cracks using the penetrant paint method.

## 5.9 Dismounting and refitting of impellers refer chapter 8 and 9

## 5.10 Additional conditions for extended warranty (>12 months)

If an extended warranty has been agreed upon, the following conditions have to be definitely fulfilled (non conformance invalidates any claim):

- this operation and maintenance manual has to be precisely followed.
- we must be informed about each maintenance/repair work undertaken and their results within 15 working days.
- among other annual checks carried out in accordance with the maintenance report mentioned under the chapter 22, an insulation test of the warm motor has to be carried out (measure the ratio of resistance to mass at 500 V DC) and recorded.

## 5.11 Typical problems

Fig. 9:

Problem	Probable causes	Measure	Elimination
Too low volume flow	False direction of rotation Pressure higher than specified Rotational speed is too less Ducts are blocked Impeller is dirty	Shutdown Consult & shutdown Consult & shutdown Shutdown Shutdown	Check the motor connection Check the construction Adjust the rotational speed Clean the ducts Clean the impeller
Very low pressure	False direction of rotation Volume flow is higher than specified Density is lower than specified Rotational speed is too less Leakage in the fan Leakage in the system	Shutdown Consult & shutdown Consult & shutdown Consult & shutdown Shutdown Shutdown	Check the motor connection Check the construction Check the construction Adjust the rotational speed change sealing change sealing
Very high power consumption	False direction of rotation Volume flow is higher than specified Pressure is lower than specified Density is higher than specified Rotational speed is high	Consult & shutdown Consult & shutdown Consult & shutdown Consult & shutdown Shutdown	Check the motor connection Check the construction Check the construction Check the construction Adjust the rotational speed
Abnormal noises	Impeller grazes defective sealing Contaminants in the casing	Shutdown Shutdown Shutdown	Check the Impeller/gap Change the sealing Eliminate contaminants Check for damages Repair
	Bearing damages Loose clamp screws	Shutdown Shutdown	Change the bearing Re-tighten the screws
Vibrations	Imbalance	Shutdown	Clean the impeller, balancing
	False direction of rotation	Shutdown	Check the motor connection
	Equipment defect	Shutdown	Align
	Very high rotational speed	Shutdown	Check the rotational speed
	Bearing damages	Shutdown	Change the bearing
	Turbulences in the System	Consult & shutdown	Check the air duct in the System
Rotational speed is too low	Slacking of the belt drive False transmission Motor overloaded	Consult & shutdown Consult & shutdown Shutdown	Tighten the belt, change Adjust the transmission Check the design
	High bearing temperature	Shutdown Shutdown Shutdown Consult & shutdown	Adjust the grease/oil quantity Change the grease/oil brands Change the bearing Cooling down
Gas odour	Defect of the shaft seal	Shutdown	Change the shaft seal
	Defect of the casing seal	Shutdown	Change the seals
	Defect of the cable seal	Shutdown	Change the seals
	Crack in the casing or cables	Shutdown	Repair

If there are disturbances that are unlisted here, we request you to shutdown and get back to us.

## 5.12 Disposal

For secure and environmentally safe disposal of process materials, spare parts or the entire fan including all the accessories, all the legally applicable specifications must be adhered to.

## 6. INSTRUCTIONS FOR STORAGE AND PROLONGED DOWNTIME (also refer chapter 1. Transport)

If the fan is not installed immediately, it must be stored in a dry and clean environment, with relative humidity not exceeding 60%, with an ambient temperature between 5 °C and 40 °C, without sudden temperature changes, free of dust, vibrations, gases or corrosive agents. If the motor is fitted with space heaters, they must always be turned on during the storage period or when the installed motor is out of operation. Otherwise it might result in damage to electric motors, cable boxes, bearings, painted surfaces and seals. It must be noted that not all paints are weather resistant, e.g mild corrosion may be caused by only a primer. Prolonged downtime may reduce the lubrication properties of grease or oil. It could lead to corrosion of the bearings. Ball bearings can develop pits. The shaft seal rings may become dry and the belts may become brittle. In order to avoid this, the fan should be operated **for about ten minutes once in 1-2 months** and if not, at least the impeller must be turned by hand. The grease in the bearings must be changed once in 3 years. If its not thoroughly maintained, then all the bearings must be changed after 3 years of downtime.

### 6.1 Precautions against accidental power supply

The operator must take appropriate measures and provide appropriate elements to avoid accidental power supply to the fan and to the accessories, especially during maintenance - and mounting tasks. For this, electrical power supply as well as other energy sources such as hydraulic, pneumatic, potential energy spring loads and draft in the duct system must be taken into consideration. Separation, switching, grounding and net locking gear must be provided by the operator to secure against accidental connection to power. The operator must comply with EN 1037: "Safety of machines – Avoiding accidental start-up".

### 6.2 Long-term storage

In addition to the listed tasks the following activities must be carried out:

- The fan bearing must be filled completely with grease when it is being lubricated.
- The fan bearing must be filled with preservative oil during lubrication.
- The belts of the belt drive must be loosened.
- A signboard marked as "not in operation" must be put up.
- Inlet- and exhaust openings must be closed air-tight.

### 6.3 Commissioning after a long term storage

- After a long intermediate storage, before mounting the fan must be checked to see if there are any faults.
- Topping up the grease or the oil of the fan bearing must be carried out to make the machine operational.
- Motor and fan bearing must be checked for its faultless status (vibration measurement) with the help of a trial run and if required must be changed.
- For fans with special sealing requirements the seals must be checked. Defective seals must be changed.
- The belts must be tightened.
- Inlet and exhaust coverings must be removed.
- If idle for a prolonged period the bearing must be changed (max after 3 years).

## 7. STORAGE INSTRUCTIONS FOR SPARE-, RESERVE-AND ABRASIVE PARTS

All the parts should be stored in a room at 15 - 25°C with a relative humidity of maximum 70%.

Variations in the temperature should be limited to max. 1°C per hour.

Roller bearings are delivered in the original packing of the manufacturer. The max. storage time is two years. After the bearings have to be exchanged.

Rubber or rubber coated spare parts such as radial packing rings, O-rings, flexible connectors, dampers and v-belts have to be protected against light and sealed in plastic wrapping. The parts should be checked for their elasticity and brittleness every year. The maximum storage is five years or less according to the manufacturer's instructions.

Metallic parts such as impellers, shafts, bushes, pulleys and bearing housings have to be checked every year. The preservation of processed surfaces has to be corrected if necessary. The bare metallic parts have to be lubricated.

## 8. FUNCTIONAL DESCRIPTION AND INSTRUCTIONS FOR INSTALLING IMPELLER-EXTRACTION DEVICE

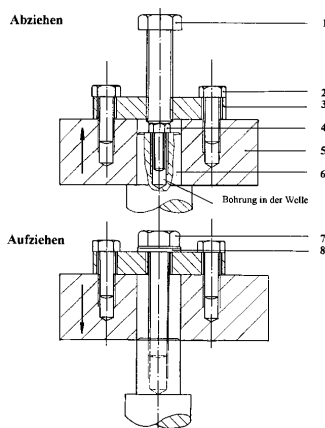
**Accessibility:** At first the impeller must be made accessible. For inlet access in centrifugal fans:

1. Take off the duct system at the inlet side of the fan
2. Remove screws at the inlet cone of the casing (includes inlet spigot, protection grill and inlet cone and/or inlet ring)
3. Carefully take off the inlet cone **Caution:** Do not damage the sealing!
4. **Note:** Measure the distance between the impeller back disc and inlet cone and maintain it while refitting.  
Variations in the distance lead to reduced performance.

In case of axial fans generally the fan must be dismantled and placed on a level surface with the impeller pointing upwards. Exceptions are swing out type axial fans and fans inside jet cowls where the impeller is accessible after opening the door.

### FUNCTIONAL DESCRIPTION

**Fig. 10:**



Serial no.	Part	Designation	Quantity
1	1	set bolt	1
2	2	fixing screw, extraction disc	2
3	3	extraction disc	1
4	4	forcing screw	1
5	5	impeller hub	1
6	6	shaft journal	1
7	7	dismounting screw	1
8	8	washer	1

For mounted impeller the screw (7) in the fan shaft (6) is tightened so that the disc (3) is tightened against the end of the shaft. The impeller hub (5) is connected through two screws (2) with the disc (3).

### Dismantling of impeller

- a) In case of corrosion rust penetrating oil must be used. The use of hammers, crowbars or other objects of force must not be used!
- b) Remove the three screws (7) and (2) and lift off the disc (3).
- c) The fan shaft bore must be covered with a set nut or - disc (4)
- d) Fit disc (3) again with the screws (2).
- e) Put screw (1) into the thread of the disc (3), as illustrated in the above diagrams. Turn it to the right until the impeller is released. Larger impellers must be guided with 2 aids.
- f) Then lift out the impeller.
- g) Remove screw (4) or the disc.

### Refitting the impeller

- a) Using the two fixing screws (2) fit the disc (3) to the impeller hub (5).
- b) Clean and lubricate the shaft and impeller bore.
- c) Lift impeller onto the fan shaft and press it slightly.
- d) Guide the screw (7) with washer into the bore of the disc (3) and screw it as deeply as possible into the motor shaft.

**Tightening torques for draw-up screw (7) and fixing screw (2)** Refer table "Tightening torque in NM" on page 7.

### Fan assembly

Carry out points 1 - 3 in reverse order. Then check the distance (measured under point 4), turn the impeller manually and check whether it turns freely.

**9. FUNCTIONAL DESCRIPTION AND MOUNTING INSTRUCTION for IMPELLERS and PULLEYS having TAPERLOCK BUSHES**

**Accessibility:** At first the impeller must be made accessible. For inlet access centrifugal fans this includes:

1. Take off duct system at the inlet side of the fan
2. Remove the screws at the inlet cone of the casing (includes inlet spigot, protection grid, inlet cone and/or inlet duct).
3. Carefully take off the inlet cone **Caution:** Do not damage the sealing!
4. **Note:** Measure the distance between the impeller back disc and inlet cone and maintain it while refitting. Variations in the distance lead to reduced performance!

For axial fans the fan in general must be dismantled and placed on a level surface with the impeller pointing upwards. Exceptions are swing out type axial fans and fans inside jet cowls where the impeller is accessible after opening the door.

**Functional description**

The hub has a conical inner bore. A conical bush that is cylindrical inside is inserted. While tightening the fixing screws, the bush is tightened and clamped between the shaft and hub.

**Dismantling of impeller**

- a) In case of corrosion rust solvent oil must be used. The use of hammers, crowbars or other objects of force must not be used!
- b) Detach all fixing screws. Depending on the size of the bush, unscrew one or two screws, oil them and screw them into the set bores.
- c) Tighten the screw(s) uniformly until the bush comes out of the hub so that the bush can move freely on the shaft.
- d) Remove the impeller with bush from the shaft.

**Remounting of the impeller**

- a) Clean and degrease all uncovered surfaces such as the bore and the conical surface of the taper lock bush as well as the conical bore of the hub. Insert the taper lock bush into the hub to coincide with all connection bores (half-thread bores must always have half-plain bores on the opposite side).
- b) Mildly lubricate and screw in threaded stud (bush size 1008-3030) and/or cylindrical screws (bush size 3535 - 5050). Do not tighten the screws.
- c) Clean and grease the shaft. Push disc with taperlock bush onto the shaft till it sets into the desired position.
- d) While using a slot key place it first into the slot of the shaft. There must be a small play between the adjustment key and bore slot.
- e) Tighten thread studs and/or cylinder screws uniformly by using a screw driver, DIN 911, with the torques provided in the table.
- f) After a short period of operation (1/2 to one hour) check torque of the screws and if necessary, correct it.

**Fig. 11:**



Bush	Starting torque of the screws [Nm]	Fixing screws		Bush	Torque of the screws [Nm]	Fixing screws		Bush	Starting torque of the screws [Nm]	Fixing screws	
		No.	Size			No.	Size			No.	Size
1008 1108	5.6	2	1/4" BSW	2012	31	2	7/16" BSW	4040	170	3	5/8" BSW
1310 1315	20	2	3/8" BSW	2517	48	2	1/2" BSW	4545	192	3	3/4" BSW
1210 1215	20	2	3/8" BSW	3020 3030	90	2	5/8" BSW	5050	271	3	7/8" BSW
1610 1615	20	2	3/8" BSW	3535	112	3	1/2" BSW				

**Fan assembly**

Carry out points 1 - 3 in reverse order. Then check the distance (measured under point 4), turn the impeller manually and check whether it turns freely.

**10. SPECIAL INSTRUCTIONS**

**10.1.1 Operation at higher temperatures (> 70°C) / Smoke proof design)**

For fans designed for operation at higher temperatures, precautions against the touching of hot surfaces (e.g. safety guards, warning signs) must be taken. In case of cold starts, the power consumption could possibly exceed the design value and the current consumption could increase to inadmissibly high values. This is especially the case when centrifugal fans are not started against a closed flap. Careful observation of the start-up is required.

The user has to secure that the cable that he inserts into the terminal box is suitable (attention if the fan unit is installed on AV mounts) and heat resistant. According to the temperature requirements, the wires inside the terminal box have to be isolated with additional glass fibre sleeve. The cable should not touch the fan casing and must be protected against mechanical damage.

Before the fan is switched off, it should be operated for some time at low gas temperatures (<100°C) until the impeller, shaft and housing have cooled down. This is to prevent heat from adversely affecting the bearings or grease at standstill. Also, the shaft shall be turned until it has cooled down, to prevent warping of the warm shaft.

The rules for correct distance away from flammable equipment must be respected at all times.

**Attention: Check bearing grease in case of accidental interruption. It can liquefy or possibly leak out.**

When using cooling discs for higher temperatures, it should be noted that adequate cooling is achieved only when the speed of rotation is sufficient. At higher impeller temperatures and low speeds (e.g. frequency converter) or when stopped (e.g. emergency stoppage or power failure), the user must cool the cooling disc externally, e.g. with a separate fan with a secured power supply.

## 10.1.2 Smoke control fans

Application and operation of smoke control fans is only allowed as agreed. Flexible sleeves, electrical connections, utilized smoke detection units and the complete smoke and heat control system must be suitable and certified. Smoke control fans must also be operatable manually (by push-button). The fans have to be maintained regularly (see DIN 31051:2019 in connection with DIN EN 13306:2018-02). They have to be installed in a way, that any inspections or maintenance works are easily to be done. If fans have been used to ventilate buildings (tunnels/carparks etc.) during emergency cases (fire) the fans have to be carefully inspected afterwards. According to the result of the inspection the fans then have to be refurbished or even replaced.

## 10.2 Gas-tight fans (refer also section 5.6)

Fans that are designed gas-tight must be checked for leakage by undertaking measurements regularly. As soon as the permissible limit values have been exceeded and there is danger to the health of humans, the system must be shut down and safety measures must be undertaken for standstill. A general room ventilation should be provided so that an unnoticed leakage will not lead to poisonous or explosive gas explosions.

In case of mounting and maintenance work, the shaft seal rings in the shaft should not be damaged. They should not be dragged over sharp edges. The sealing rings must run exactly centred on the shaft. The total value of shaft eccentricity and offset should not exceed 0.3 mm. On account of this, the transport-instructions must be carefully observed! Scratches, pressure marks, rust or other damages to the shaft surface at the sealing ring position lead to leakage. The sealing lips should never be dry. After re-mounting, a gas-tightness check must be carried out again. In case of imbalance and abnormal fluctuations and also after dismounting and re-mounting of impeller, a check needs to be undertaken.

## 10.3 Frequency converter/ softstarter / speed regulation

The frequency converter must be set so that unnecessary high loads due to high acceleration or deceleration are avoided. In general, the start-up time for an impeller with diameter 1000 mm should be at least 30 seconds, between 1000 and 2000 mm at least 60 seconds and for larger diameters 120 seconds.

In order to avoid unnecessary loads during continuous accelerations and decelerations which can lead to material fatigue, the control should be made as slow as possible.

Accelerations and decelerations coming from the process control should not be larger than **0.45 rad/s<sup>2</sup>** (corresponding to a speed change of **258 rpm per minute**, or **4.3 rpm per second**) except when passing through resonance frequencies.

**Material fatigue in the impeller and other parts of the fan is reported to have occurred due to very frequent speed changes. The impeller should be replaced after, at the most, 0.5 million speed changes (corresponds to a life time of 30 years at 2920 operating hours/year and 6 speed change per hour).**

The maximum voltage peaks at the motor terminals must be less than 1600V for 400V motors (less than 2400V for 690V motors); and the dU/dt values must be less than 5000V/μs for 400V motors (less than 7800V/μs for 690V motors)!

If resonance frequencies are passed through often during speed changes (which must be blocked in frequency converter), an even lower life expectancy may result.

**Warning:** After disconnecting the power supply to the frequency converter, at least 10 minutes must pass before the cable or components of the converter can be touched since there is risk of serious injury from stored energy in the capacitors. Even control cards can lie at the potential of main power circuit. Always measure the voltage before touching and ground.

Before mounting and commissioning the special instructions of the manufacturer of the motor and the frequency converter must be absolutely adhered to.

General instructions for mounting frequency converters

- The engine and converter should be placed as closely together as possible to minimize the electromagnetic interference and must be tuned to each other
- Cables must be shielded and should not be longer than specified by the manufacturer (respect additional instructions for sensors!)
- Cables, cable shields, frequency converter and engine must be grounded
- Additional filters may be necessary to minimize radio interferences.

**Attention:** If a softstarter is used to brake the fan take care that it is switched off shortly before standstill to avoid pendulum effects. Pendulum effects can destroy the complete fan unit!

## 10.4 Thermal safety

Fans or components that can become hot above 70°C and less than -10°C cold, must be protected on site, insulated or must be provided with warning (EN 563). It should be noted that parts such as bearing casings can become very hot sometimes, but, they must not be insulated since heat accumulation can damage the bearings.

Shut down / Shut off:

For hot air- or hot gas fans, it must be ensured that the heat flow is interrupted to the pipelines. Please take care that the fans are cooled with cooling medium with cooling discs before switching off since even the effect of cooling discs is interrupted due to switching off due to hot state and it can lead to overheating (for e.g. on the bearings). If this is not possible, resources that lie outside are to be cooled separately.

## 10.5 Fans according to pressure- devices – Directive 2014/68/EU

All fans operating with a maximum allowable pressure above 0.5 bar, which are put on the European market, are considered to be pressure equipment covered by the Pressure Equipment Directive (see Directive 2014/68 / EU). In Germany it is implemented into national law in the Pressure Equipment Provision that regulates the placement of pressure equipment on the market. Moreover, in Germany the Product Safety Act, which applies to products put on the market, a number of EU directives is implemented into German law, including the Directive on Simple Pressure Vessels and Pressure Equipment Directive. If compliance with the guidelines is secured and if appropriate usage does not endanger the safety and health of persons, the manufacturer is allowed to mark the product with a CE marking, provide the required documentation and place the product on the market. In the Ordinance on Industrial Safety (formerly in the Pressure Vessel Regulation) the Work Equipment Directive (see 2009/104 / EC) is implemented into German law. Therein the testing at pre-commissioning and testing of specific pressure equipment is regulated. The operator has to protect the fan on the plant with safety equipment according to the regulations against excessive pressures and to perform a regular maintenance. The operator shall be responsible for the correct testing according to the relevant and applicable directives, i.e. TRBS 1201 (inspections of work equipment and systems requiring monitoring).

## 10.6 ATEX- fans – general instructions, additional standards and instructions

The fan has a labeled earthing connection to which the operator must ground the fan with the entire system. To avoid danger of burning, no rust or rust film can form in the components with aluminum and no iron oxide-contained and light metal-contained paints can be used. Additional measures by local or legal requirements, standards or edicts have to be followed. The specified distance between the rotating and stationary parts was maintained during the construction of fan. The fan must be stopped immediately in case of imbalance or abnormal fluctuations and the error must be rectified. After dismounting and remounting of impeller, the distances must be checked.

As the manufacturer of fan, it must be pointed out that all relevant details about medium (components, concentration, temperature...), for operation (pressure difference, volume flow...) and for Ex-Zone are to be retained.

### Instructions:

- For explosive environments, it must be ensured by the operator that the used device category corresponds to the directive 2014/34/EU of these Ex zones according to the directive 1999/92/CE.
- For fans for increasing the (earthing-) gas pressure, we must refer to the "Guidelines for construction, maintenance and operation of gas compressors with an operating pressure up to 1 bar – G6" of Swiss Gas and Water Industry Association (SVGW).
- The installer/ system constructor/ operator is responsible for switches required, flaps, valves, flame blocks and detonation fuses for ensuring safety of the entire system in operation, and also during shut down and after shut down. During the construction of flame blocks and detonation fuses, special requirements are to be adhered to in accordance with DIN EN ISO 16852:2017-04.

**General**

- The danger zone due to flying parts in case of high pressure fans is basically in the radial direction.
- While setting up in an Ex-Zone, the fan must be suitable for this zone and must be labeled.
- For avoiding the danger of burning, rust or rust film should not be present in fans and pipelines under any circumstances.
- Dust in the feed medium is permissible only if this is mentioned in the data sheet. The fan is fitted specially for this. There is danger of deposits in case of Impermissible dust load. Thus, there can be imbalance leading to sparking. Dust clouds and deposits can get ignited.
- Undertake regular cleansing of components of adhering dust.
- Systems that are set up for operation with explosion-prone mixtures must have a grid with a max. mesh size of 12 x 12 mm at the inlet and outlet openings to keep the foreign particles away. A dust hood must be provided to protect against vertical falling in. The openings must be installed at a well-accessible and controllable site.
- The permissible feed medium and also the limiting values for temperature, if necessary, even the dust content and moisture, is to be fixed in the data sheet. Using fan for other media or outside the specified limit values is not as intended and not permissible.
- The fan is provided with corrosion protection as specified on the data sheets or a coat of paint. No iron oxide-contained and light metal-contained paints are used on fans for the ex-area even for subsequent coats. Ex-motors should not be given subsequent coats without written permission of manufacturer.
- The fan is provided with a labeled earthing connection to which it must be grounded with the entire system.
- The gap at the impeller inflow must be at least 2 mm. For diameters above 200 mm, the value of 1% of the largest possible contact diameter must be taken, but, a maximum of 20 mm. This is generally applicable even for shaft seal casings and safeguards.
- It must be inspected whether it is maintained and is not reduced due to, say, bearing abrasion.
- If provided, sealing air and/or suction need to be connected to the shaft seal. Overpressure or under-pressure as well as throughflow must be ensured during the operation.
- If available, automatic grease emitters are to be activated.
- Please take care of the provided gas- discharge. In case of too high discharge, it can lead to overload of engine, for too low or blocked discharge, it can lead to overheating of fan and dangerously high surface temperatures. If not specified otherwise, the volume flow must lie within -10% to +20% of the standard- volume flow.
- Exclusively, anti-static or electrically conducting driving belt must be used.
- Centrifugal fans maybe equipped with three Anti Spark Bolts located on the drive side casing. These prevent the impeller from striking the casing during a malfunction. **DO NOT TAMPER!**
- The gas path of the fan must always be free so that the medium in the fan is not heated unnecessarily.
- After dismantling the fan, the remaining pipelines are to be closed. For dismantled fans, the operator needs to ensure that the deposits in the fan do not pose danger to humans and the environment. Clearance must be given by the operator in case of health-hazardous media.

**Maintenance:**

- In order to ensure proper operation of blower, a revision needs to be undertaken after 20000 hours of operation, latest after 36 months. Revisions must be undertaken only by the manufacturer or by authorized personnel of the manufacturer.
- In case the environmental temperature lies above 30°C over a longer period of time or the storage temperature exceeds 70°C, the above time periods must be reduced.

**Temperature:**

- The environmental temperature should not exceed 40°C.
- The fan for explosible environment must be designed and operated such that it is not heated up unnecessarily at any place, neither due to inherent heating nor due to external heating. The temperature class is fixed depending on the medium and the fan design in data sheet. The limit values according to DIN EN ISO 80079-36:2016 are given subsequently:

Temperature class	Maximum permissible surface temperature
T1	450°C
T2	300°C
T3	200°C
T4	135°C
T5	100°C
T6	85°C

- The gas temperature can increase above 70°C depending on the operating point, above all, at high pressures and small volumes. In this case, there is **danger of combustion / injury** in case one touches the surface. If the temperature is above 70°C during commissioning, trial runs or in later operation, the operator needs to undertake measures required for protection of people and things. (Warning signs, insulations).

**Monitoring:**

Monitoring	Limit value	Measures after triggering
Temperature monitoring PT100 at film cut-out (FDS)*)	60°C Pre-alarm	Check blocking of throughflow.
	90°C Alarm (in case of fire)	Interruption of gas inlet within 30 sec, immediate switching off. <b>In case of fire, exchange of FDS required.</b>
Storage temperature monitoring PT100*)	90°C pre-alarm	Eliminate cause for heating (Insufficient lubrication, Over-lubrication, damages to bearings ...)
	105° Alarm	Immediate switching off of fan
Casing temperature monitoring*)	T1 315°C T2 210°C T3 140°C T4 94°C	Switch off the fan, eliminate cause for overheating (too little air flow, stopped FDS, missing casing cooling...)
Blocked air monitoring*)	min .0.5 m³/h max. 1.8 m3/h, but min. 30% above normal value during commissioning	Eliminate the cause for missing air (blocked pipes, tearing off of tube, breakdown of gas supply...)
	After 15min of pre-alarm	Switching off of fan

\*)if provided on fan

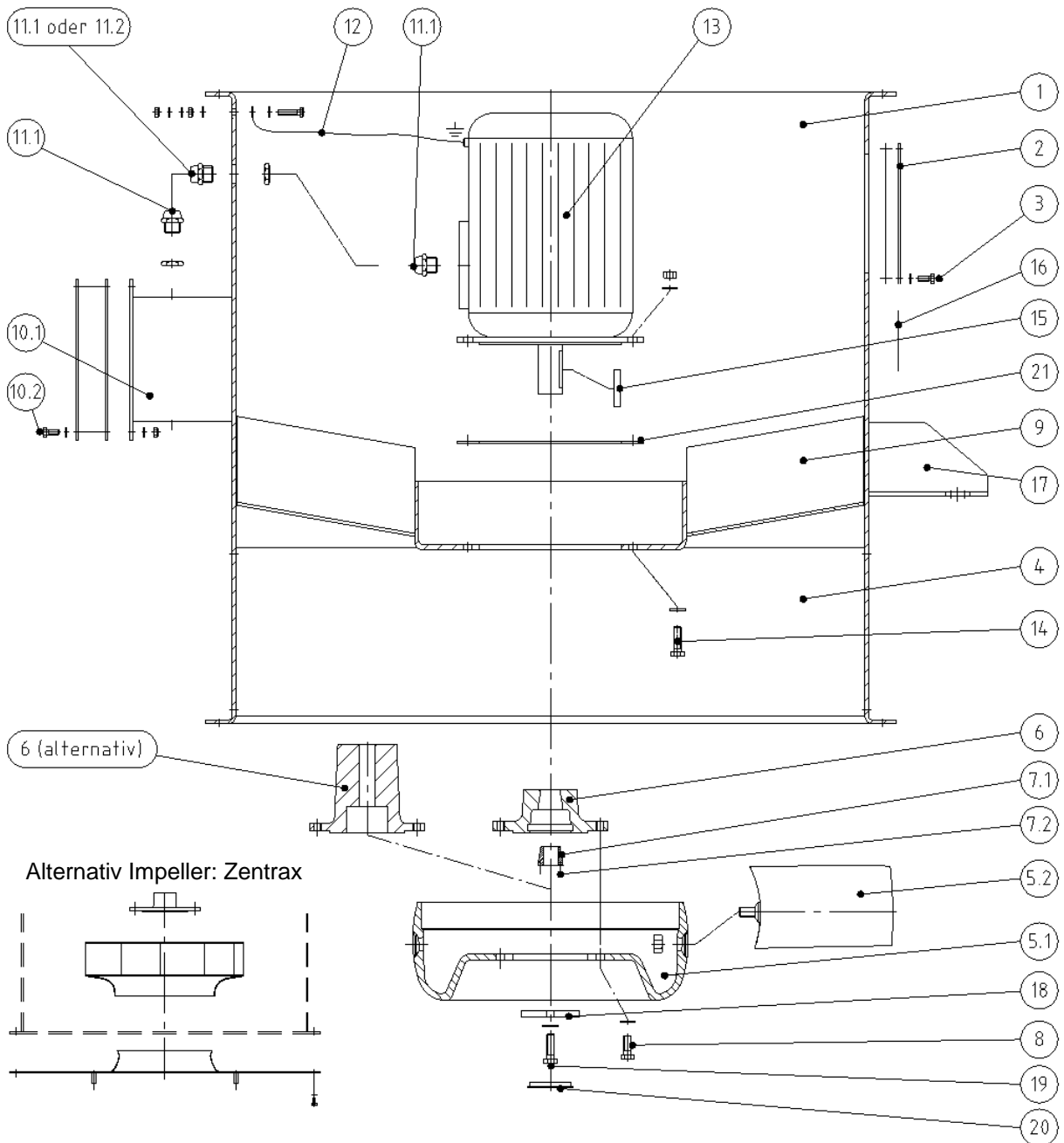
**11. AVAILABILITY / ABRASIVE PARTS**

The goal is to achieve high availability of fan, avoid deficiencies and to exclude breakdown. The pre-requisite is proper working, checking the function, prompt maintenance and availability of abraded- and spare parts. The following belong to abrasive parts amongst others: Anti-friction bearings – V-belt/ Flat belts- pulleys in case of heavy stress – elastic supports- vibration damper – Seals – Seal rings – Couplings – impeller in case of abrasive operation.

A report is undertaken for checking the status. This report is provided with date and signature by the examiner (refer to Section 22.).

## 12.1 AXIAL FAN (ZENTRAX)

Fig. 12:

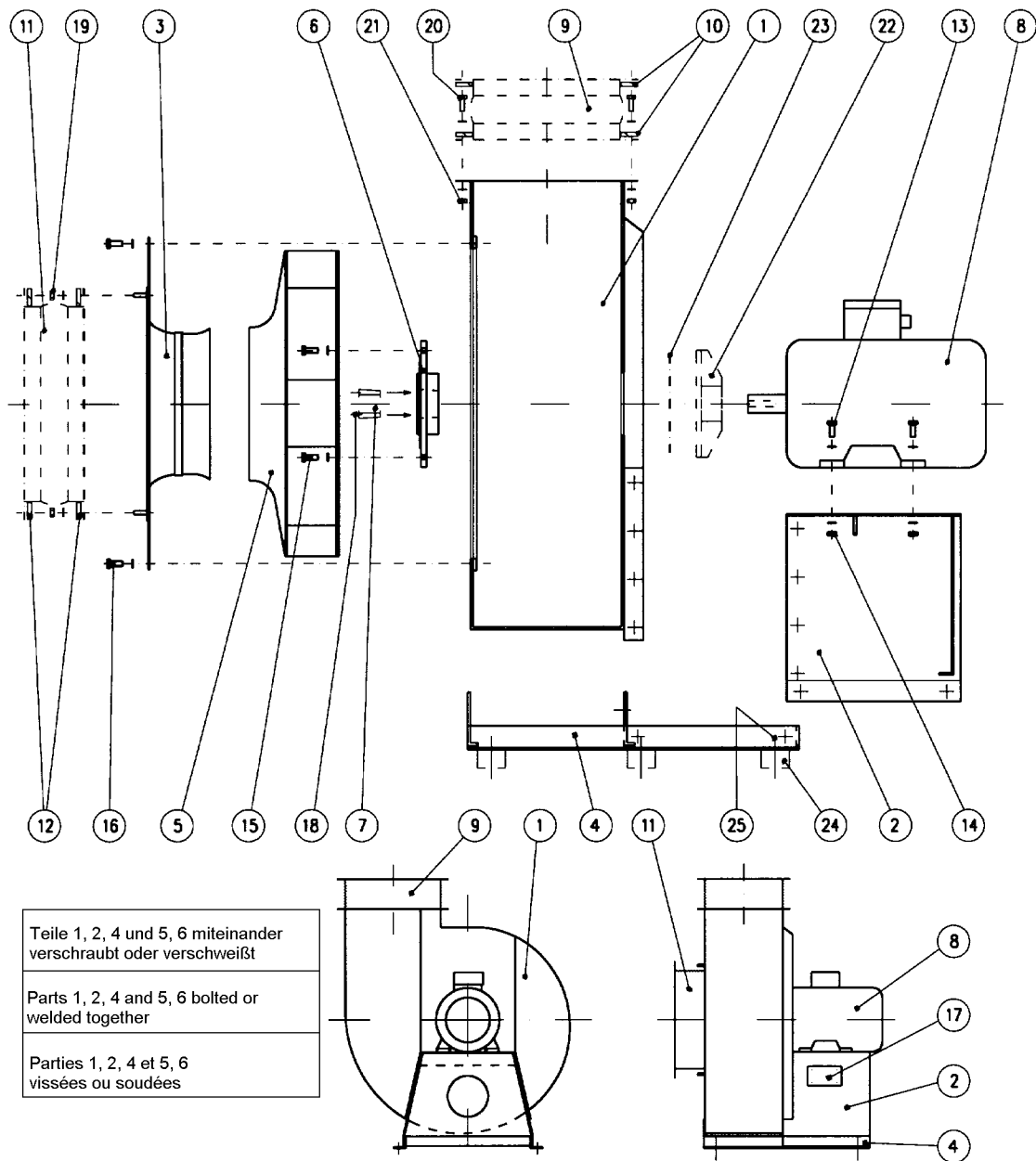


Part	Description	Part	Description	Part	Description	Part	Description	Part	Description
1	Casing	5.2	Impeller Blade (optionally Christmas Tree® reinforced)	9	Control Unit	12	Earthing Cable OPT	17	Mounting bracket (OPT)
2	Inspection opening to	6	Hub core taperlock bush (alternative tighter hub core)	10.1	Terminal Box IP54 (IP55) with cover and sealing	13	Engine	18	Support Plate
3	Bolt for inspection opening to	7.1	Taper lock bush i.a.	10.2	Bolt for Terminal Box	14	Motor fixation bolt	19	Bolt for Support Plate i.a.
4	Anti-sparking lining OPT	7.2	Bolt for taper lock bush i.a.	11.1	Cable Gland	15	Key	20	Plastic Cap i.a.
5.1	Impeller hub	8	Bolt for hub core	11.2	Cable Duct	16	Name Plate + Arrow indicating sense of rotation	21	Distance ring i.a.

OPT= optiona

i.a = if available

Fig. 13:



Teile 1, 2, 4 und 5, 6 miteinander verschraubt oder verschweißt

Parts 1, 2, 4 and 5, 6 bolted or welded together

Parties 1, 2, 4 et 5, 6 vissées ou soudées

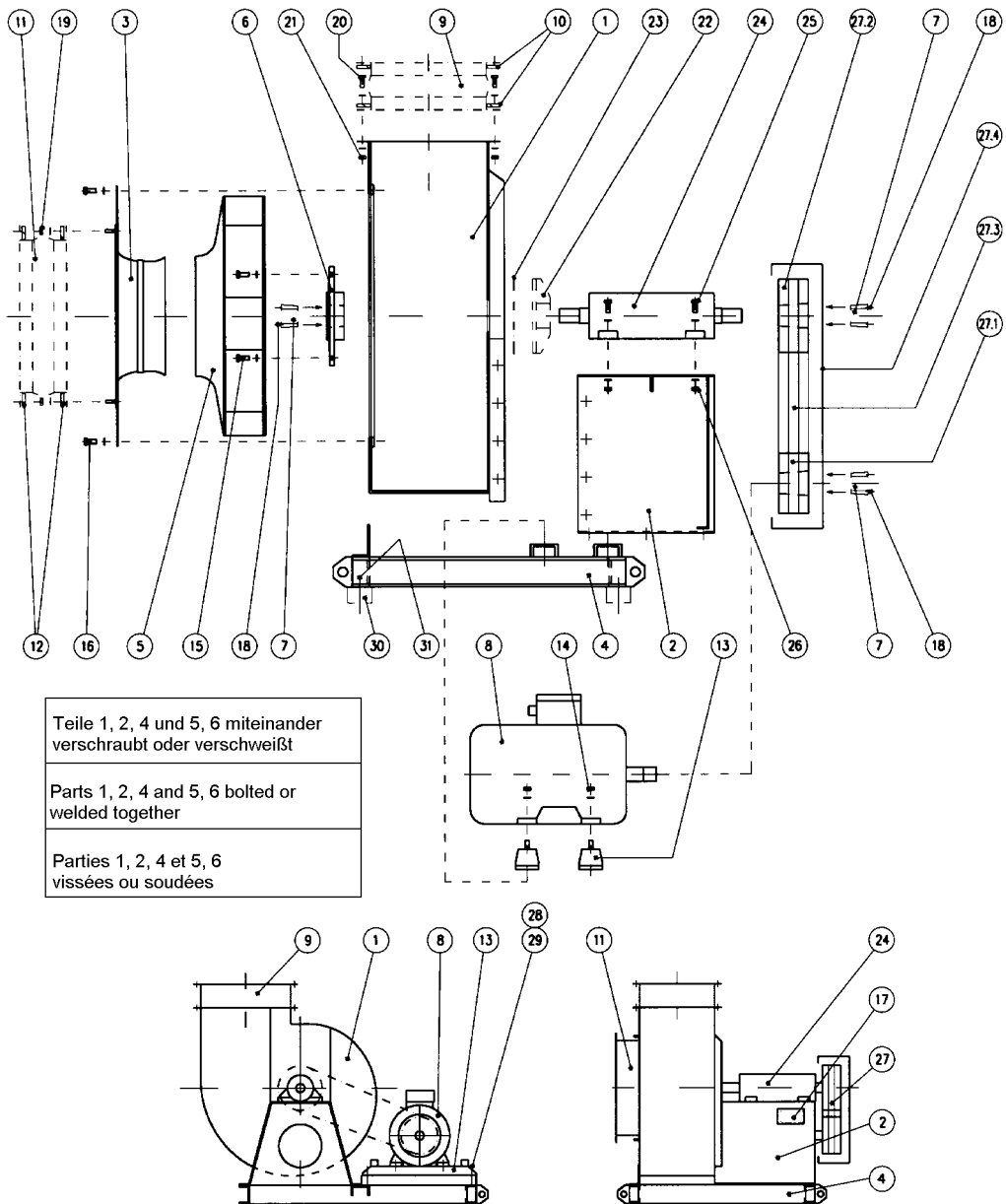
Part	Description	Part	Description	Part	Description	Part	Description	Part	Description
1	Casing	6	Impeller hub	11	Flex. Connection inlet OPT	16	Hexagonal bolt and U-disk	21	Hexagonal nut and U-disk OPT
2	Motor pedestal	7	Taper lock bush w.v.	12	Counter flange for inlet flex. connection OPT	17	Nameplate WITT GROUP	22	Cooling disc with guard OPT
3	Inlet nozzle	8	Motor	13	Hexagonal bolt for motor foot	18	Bolt for taper lock bush w.v.	23	Shaft lining w. v.
4	Base frame	9	Flex. Connection at outlet OPT	14	Hexagonal nut and U-disk for motor foot	19	Hexagonal nut and U-disk OPT	24	Vibration damper OPT
5	Impeller complete	10	Counter flange outlet for flex. Connection OPT	15	Hexagonal nut and U-disk for impeller hub	20	Hexagonal bolt and U-disk OPT	25	Hexagonal nut or bolt (depending on the vibration damper) OPT

OPT= Optional

w.v. = if available

## 12.3 CENTRIFUGAL FAN DESIGN 2 (drive via V-belt)

Fig. 14:

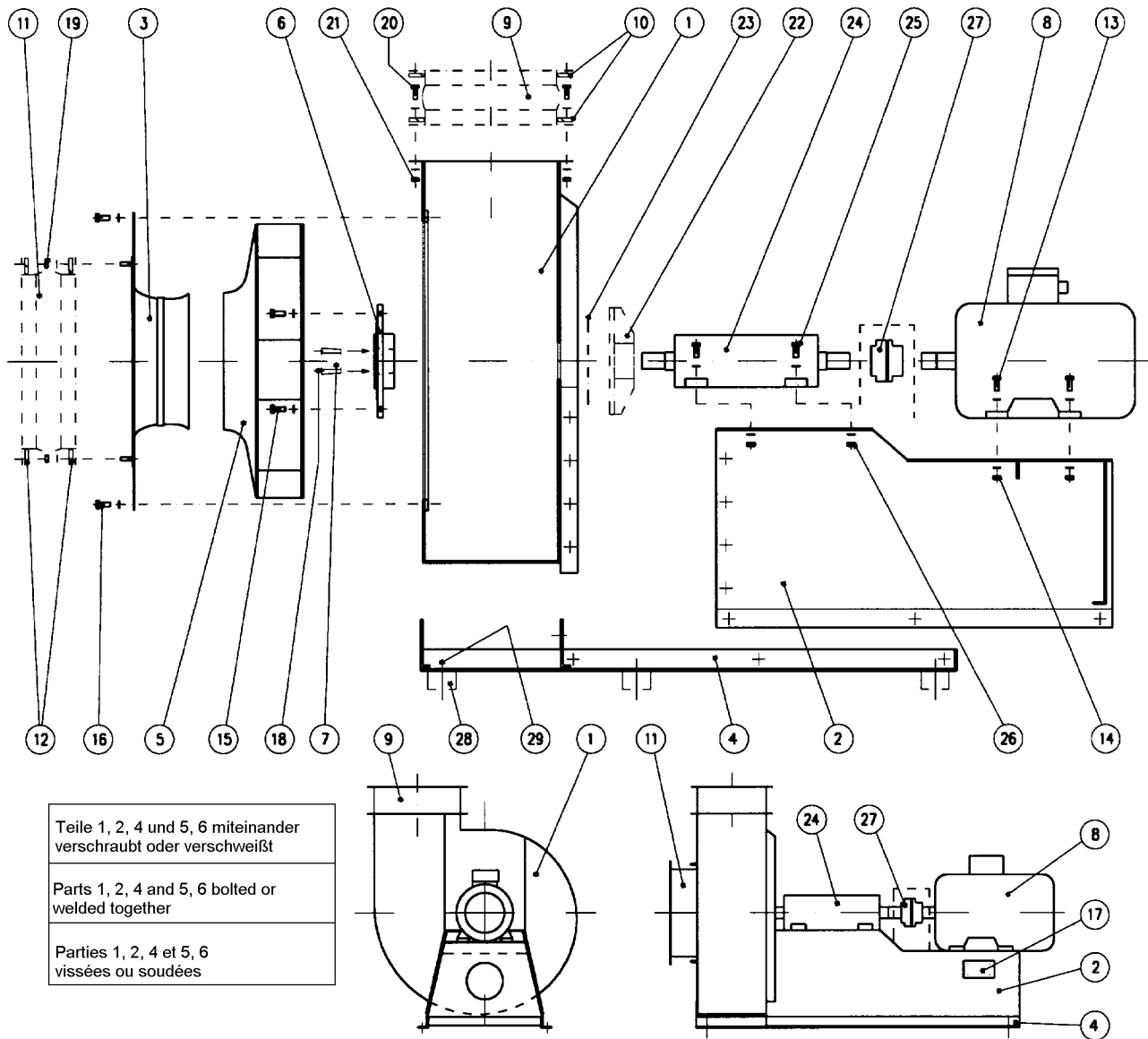


Part	Description	Part	Description	Part	Description	Part	Description	Part	Description
1	Casing	8	Motor	15	Hexagonal bolt and U-disk for impeller hub	22	Cooling disk with guard OPT	27.2	Pulley of bearing
2	Bearing pedestal	9	Flex. support pressure-side OPT	16	Hexagonal bolt and U-disk	23	Shaft lining w. v.	27.3	V-belt
3	Inlet nozzle	10	Counter flange for outlet flex. Connection OPT	17	Name plate WITT GROUP	24	Block bearing	27.4	V-belt guard
4	Base frame	11	Flex. Connection (inlet) OPT	18	Bolt for taper lock bush w.v.	25	Hexagonal bolt for block bearing foot	28	Hexagonal bolt and U-disk for stretching rail
5	Impeller complete	12	Counter flange outlet flex. Connection OPT	19	Hexagonal nut and U-disk OPT	26	Hexagonal bolt and U-disk for block bearing foot	29	Hexagonal nut and U-disk for stretching rail
6	Impeller hub	13	Stretching rail	20	Hexagonal bolt and U-disk OPT	27	V-belt drive	30	Vibration damper OPT
7	Taper lock bush w.v.	14	Hexagonal nut and U-disk with motor foot	21	Hexagonal nut and U-disk OPT	27.1	Pulley of motor	31	Hexagonal nut or bolt (depending on the vibration damper) OPT

OPT= optional

w.v. = if available

Fig. 15:



Part	Description	Part	Description	Part	Description	Part	Description	Part	Description
1	Casing	7	Taper lock bush w.v.	13	Hexagonal bolt for moto foot	19	Hexagonal bolt and U-disk OPT	25	Hexagonal bolt for block bearing foot
2	Motor-/bearing pedestal	8	Motor	14	Hexagonal bolt and U-disk for motor foot	20	Hexagonal bolt and washer OPT	26	Hexagonal bolt and U-disk for block bearing foot
3	Inlet nozzle	9	Flex. Connection outlet side OPT	15	Hexagonal bolt and U-disk for impeller hub	21	Hexagonal bolt and U-disk OPT	27	Coupling with coupling protection
4	Base Frame	10	Counter flange for outlet flexible connection OPT	16	Hexagonal bolt and U-disk	22	Cooling disk with guard OPT	28	Vibration damper OPT
5	Impeller complete	11	Flexible connection (inlet) OPT	17	Name plate of WITT GROUP	23	Shaft lining w. v.	29	Hexagonal nut or bolt (depending on the vibration damper) OPT
6	Impeller hub	12	Counter flange inlet flexible connection OPT	18	Bolt for taper lock bush w.v.	24	Block bearing		

OPT= optional

w.v. = if available

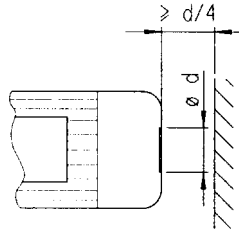
## 13. ELECTRIC MOTORS

The guidelines and safety instructions of the manufacturer must be strictly adhered to.

By nature, fans are machines with relatively high inertia. This is especially the case for large impellers with relatively low speed, i.e. a motor with a relatively low power and small torque. Therefore, the start time should be checked if the fan speed is smaller than the motor speed and for all motors above 10 kW. Due to customary short relay times, one should not avoid to use relays for extra heavy starts or centrifugal couplings.

**Fig. 16:**

The cooling should **not be obstructed** and the exhaust air- also adjacent devices- must not be reused.



attention is necessary when single phase employed as these motors generally have unfavorable torque curve.

Special motors are an extremely

### 13.1 General

Low-voltage machines have dangerous, **live and rotating** parts and also possibly, **hot** surfaces. All work regarding transport, connection, commissioning and maintenance must be carried out by **qualified** technical personnel (prEN50110-1/VDE 0105, IEC 364). Improper handling can cause **damages to people and things**.

### 13.2 Intended use

Low voltage machines match with the harmonized standards of the series **EN 60034 (VDE 0530)**. The use in **ex-areas is forbidden**, unless **explicitly** provided for this purpose (Refer to additional instructions). Protection types  $\leq$  IP 23 **should not be used** in the open. Air-cooled designs are to be measured for environmental temperatures of **-20°C to +40°C** and also installation heights  $\leq$  **1000 m** over NN. Deviating specifications on the rating plate must be adhered to **strictly**. The conditions at site must match **all** specifications on the rating plate.

Low voltage machines are **components** for installation in machines as per the machine directive 2006/42/EU. The **commissioning** is not permissible until conformity of end product has been established with this directive (note also DIN EN 60204-1).

### 13.3 Installation/ mounting

Ensure an even supporting surface, good foot- and flange fixture and exact alignment for direct coupling. Avoid structural-conditioned resonances with rotary frequency and doubled power frequency. Turn the rotor **by hand** and listen to unusual grinding noises. **Control** the **direction of rotation** in uncoupled state.

Pulleys and couplings are to be mounted / dismantled **only** with suitable tools (heating up!) and must be covered with a **shock protecting device**. Avoid impermissible belt tensions (technical list). The force status of the low voltage machines is specified on the shaft mirror or rating plate (H = half key, F = full key). In case the motor has a half key (H), the coupling must be balanced with a half key. **Projecting, visible** key parts are to be removed.

Designs with shaft ends are to be provided with a cover upwards **at site** which prevents the foreign bodies from falling into the fan.

Condensation can occur in the motor casing for certain environmental conditions. This can be avoided with standstill heating or placing low voltage on the motor winding. The condensate- drainage openings on the motor must be opened regularly or must be checked in the opened state.

The operator must protect the drive motor against overload. There are processes such as feeding hot gases or high reduced pressure on the fan for which the motor is not designed for operating at environmental pressure and temperature. For start up and possibly required running, the power consumption must be reduced, say, by partial closure of channel with flaps, operating at lower speeds or checking the inlet vane.

Often used low voltage- asynchronous motors with cage rotors fulfill the requirements of EG-directive with regard to electromagnetic tolerance when operated at electric power supply according to DIN EN 50160:2020.

When fed with a converter, different, heavy interference emissions occur depending on the design of converter. In order to avoid exceeding the limit values in accordance with DIN EN 61000-6-3:2002-08, VDE 0839-6-3:2002-08, DIN EN 61000-6-3:2005-06, VDE 0839-6-3:2005-06, DIN EN 61000-6-3:2007-09, VDE 0839-6-3:2007-09, DIN EN 61000-6-3:2011-09 and VDE 0839-6-3:2011-09 for the converter/motor drive system, the EMV-instructions of the converter manufacturer have to be strictly adhered to. For motors with in-built sensors (for e.g. resistors), interferences can occur on the sensor cable conditioned by the converter. The motor needs to fulfill in principle the requirements of interference immunity.

For motors with in-built sensors (for e.g. resistors), the operator himself must ensure sufficient interference immunity by proper selection of sensor- signal cable and of evaluation device.

### 13.4 Electrical connection

All work must be carried out only by **qualified** technical personnel on the **idle** low voltage machine in visibly **activated** state **secured against restart**. This is applicable even for auxiliary circuits (for e.g. standstill heating). **Check whether the system is disconnected!**

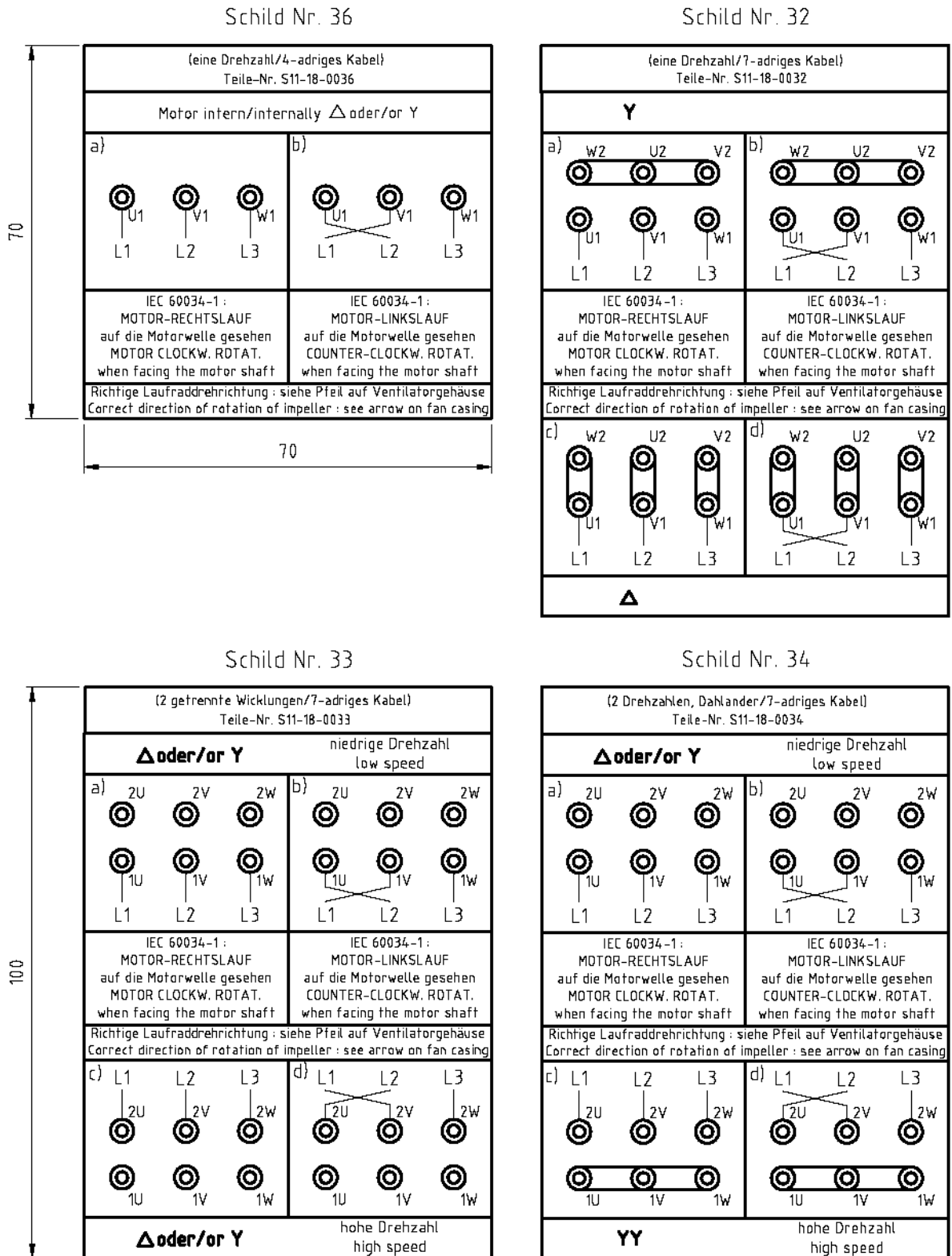
Adhere to specifications on the rating plate as well as the wiring diagram in junction box.

Exceeding the tolerances in EN 60034-1 / VDE 0530, Part 1 - Voltage  $\pm 5\%$ , Frequency  $\pm 2\%$ , and also unfavorable curve shape or missing symmetry – increases the heating and influences the electromagnetic tolerance.

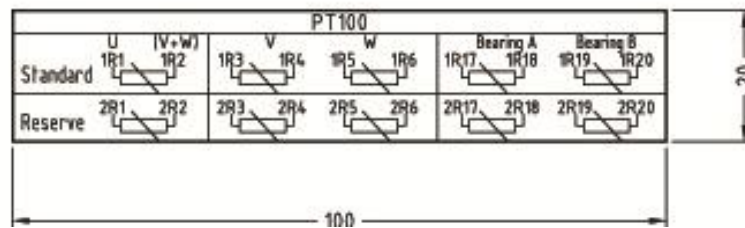
The connection must be undertaken such that a **permanent, secure** electrical connection is obtained (no dangling wire ends); use dedicated cable ends. Make **ground wire connection**. The free cable length in between fan and building and its fixing method have to follow the actual VDE standards. Metal cable glands installed into plastic terminal boxes must to be earthed.

The smallest air gaps between blank, live parts and against earthing should not be less than the following values: 8 mm for  $U_N \leq 550$  V, 10 mm for  $U_N \leq 725$  V, 14 mm for  $U_N \leq 1000$  V. The junction box must be free from foreign bodies, dirt and humidity. Close cable glands that are not used and the box such that they are **dust-** and **water-proof**. Secure **half keys** for trial run without downthrust elements. **Check** the smooth functioning of **brakes** for low voltage machines with brakes before commissioning.

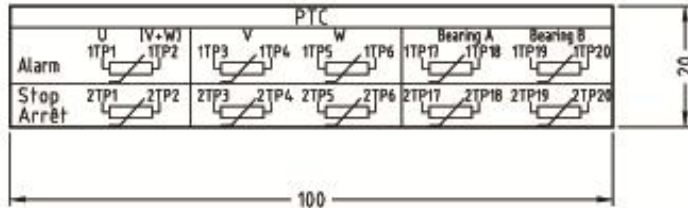
Fig. 17:



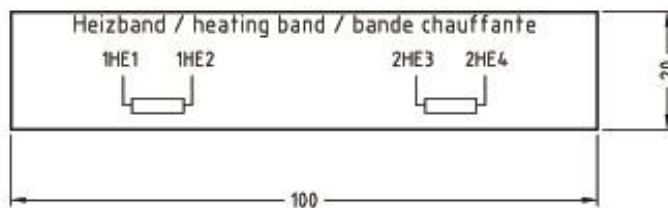
Schild Nr. 37



Schild Nr. 38



Schild Nr. 39



### 13.5 Operation

Vibration levels  $v_{eff} \leq 3,5 \text{ mm/s}$  ( $P_N \leq 15 \text{ kW}$ ) or  $4,5 \text{ mm/s}$  ( $P_N > 15 \text{ kW}$ ) are safe for normal operation. In some cases, higher values are to be expected, refer to ISO 14 694. In case of changes compared to the normal operation – for e.g. **increased temperatures, noises, vibrations** - the cause must be established, if necessary, referring to the manufacturer. Safety devices should not be disconnected even in trial operation. Switch off fan in **case of doubt**. Clean the air passages regularly if dirty. Regrease bearings with regreasing device when motor is **running**. Adhere to type of lubrication! In case the grease outlet bores are closed with stoppers (IP 54 Shaft side: IP 23 Shaft side and cooling side), **remove stoppers** before greasing and then close again thereafter. Bearings to be replaced according to the specifications of the manufacturer or **Section 5.5.3**. Monitoring equipment (vibration, volume flow, pressure, stall, etc.) should be evaluated after having reached a stable operating condition (e.g. 60 seconds after reaching the operating speed).

### 13.6 Minimum speed/ maximum speed

If a fan has been designed for speed-controlled operation, the **minimum speed** should not be less than **30% of the nominal speed**. If lower speeds are required for the system, special permission (= recalculation of drive motor/ checking the bearing) is required for the same. **Maximum speed -> Refer to Section 4.5**

### 13.7 Starting/ Stopping/ Reversing

Due to high moment of inertia of fan-impellers, a fan may be started, stopped or reversed maximum 6 times in an hour. At least a time span of 2 minutes must be maintained between two subsequent switching processes. If higher switching cycles are required for the system, special permission (= recalculation of drive motor/ checking the drive motor) is required for the same. **Attention: Axial fans type LF with motor output of 7,5kW or more may only be started with star-delta connection (or frequency converter)!**

### 13.8 Drain plug for condensation

Motors with closed plugs for condensation (i.e. very dusty environment) have to be regularly opened according to motor makers manual (i.e. during maintenance), so that condensation is allowed to escape from the motor. Take care that the way out for condensation is not blocked and that the drain plugs face downwards.

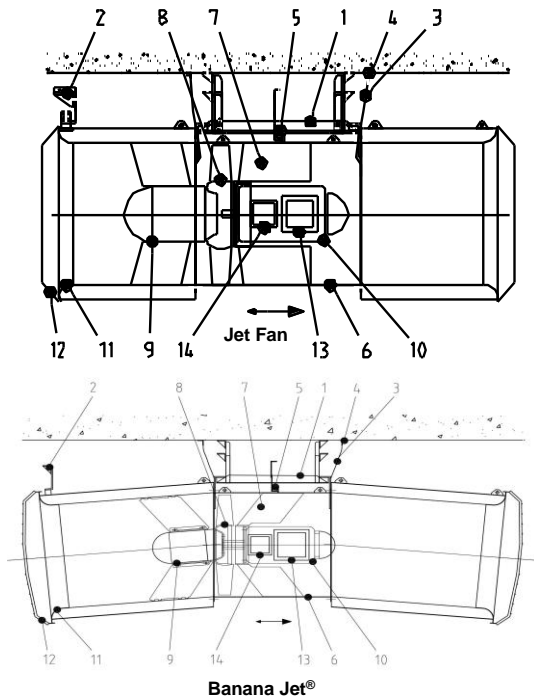
### 13.9 Transport, storage

**Damages** found must be reported **immediately** to us. The **commissioning** may be delayed. Tighten the screwed transport bolts securely. They are designed according to the weight of the low voltage machine, do **not** apply additional loads. **Remove transport fastenings** before commissioning. Re-use for further transports. If low voltage machines are stored, ensure **dry, dust-free and vibration-free** environment ( $v_{eff} \leq 0,2 \text{ mm/s}$ ). Measure the insulation resistance before commissioning. Dry the winding for values  $\leq 1 \text{ k}\Omega$  per Volt of measured voltage. Follow the "Storage instructions".

## 14. TUNNEL- FANS

### 14.1 Description

Fig. 18:



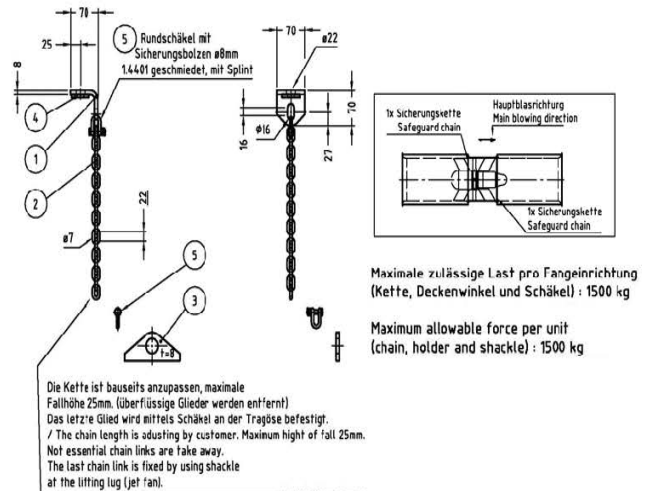
A jet fan and a Banana Jet® consists of the following components:

1. Suspending construction
  2. Anti-swing device (optional/ for silencer length > 1500 mm)
  3. Catch ropes or securing chains (depending on size 2, 4,6 or 8 pieces)
  4. Mounting bracket for catch rope/ securing chains
  5. Tear-off monitoring (electrical switch)
  6. Jet fan housing
  7. Guide vane
  8. Impeller
  9. Pre-guide vane (if required)
  10. Motor
  11. Suction nozzle or silencer (one side or both sides)
  12. Protection grill (one side or both sides)
  13. Junction box
  14. Auxiliary junction box (if required)
- (Optional components: 1/2/3/4/5/9/11/13/14)

### 14.2 Installation

1. The type, number and size of anchor bolts depends on the quality of tunnel ceiling. If the pin is not given in our drawings, please ask the civil engineer.
2. The bore holes are to be marked on the tunnel ceiling using a template and drilled according to the instructions of the manufacturer (back cut, cleaning etc.).
3. Fasten the anchor bolts, undertake load test according to the manufacturer's specification (by load device /torque or the like)
4. Lift the jet fan and the suspending construction to the tunnel ceiling/ adjust all loose bolt connections.
5. Tighten all screw connections (refer to the following table for torques)
6. Check the alignment again and if need be, re-adjust the screw connections on the suspending construction.
7. Mount the anti-swing device (if available).
8. Install tear-off monitoring, adjust the electrical switch.
9. Mounting the catch rope/ chains on the tunnel ceiling with appropriate mounting angles, thimbles and rope grips (Details refer to drawing on the right). A slack of about 10 mm must be maintained.
10. Make all electrical connections.
11. Inspect surface protection. If necessary, improve the paint supplied with fan.

Fig. 19:

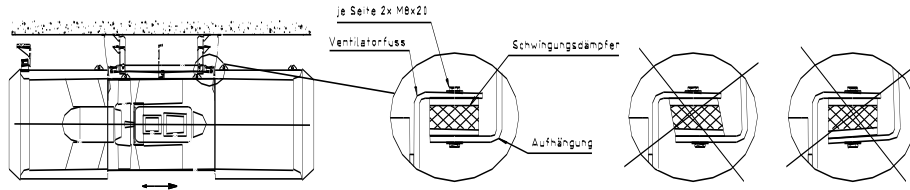


Part	Description	Part	Description
1	Holder	4	Plate
2	Chain (GK 5)	5	Shackle with bolt, nut and cotter pin
3	Lifting lug at the fan		

**ANCHOR INSTALLATION WARNING:** When installing ceiling or wall anchors, the requirements of the anchor manufacturer (see packaging or leaflet) must take priority over all other information! If we have given values for setting depth, torque, etc. that differ from the information of the anchor manufacturer, you must contact us to clarify any discrepancies before any works are carried out. The dimensions of the mounting structure with the planned drilling dimensions must be verified before placing the anchor since, as a result of welding tolerances, larger deviations are possible. Failure to follow this procedure may result in the anchor not being correctly positioned and no longer being certified.

## 14.3 Common mounting errors

Fig. 20:



## 14.4 Marking

All jet fans are equipped with a name plate near the terminal box, on which all information important for the operator are given along with the machine number (important for future spare part orders). The rated power of electrical drive motor and also the rated current belong to this. An electrician is able to connect the jet fan to the switchboard at site with these two parameters.



<b>WITT GROUP</b> CE		Ziegeleiweg 38	
Witt & Sohn AG		D25421 Pinneberg	
UK		Made in GERMANY	
CA			
Bez. _____	Designation		
Type _____			
No. _____	Jahr/ Year _____		
$q_v$ m <sup>3</sup> /h _____	$\rho$ kg/m <sup>3</sup> _____		
$P_{sf}$ Pa _____	$P$ kW _____		
$P_t$ Pa _____	$t$ °C _____		
$n$ 1/min _____	$t_{max}$ °C _____		
Position _____			
<b>Motor</b>			
Baugröße/ Size _____	U _____	V _____	f _____ Hz
Polzahl/ Pol no. _____	Isolationskl./ Insulation cl. _____		
Bauform/ Design _____		Schutzart/ Protection cl. _____	
Nennleistung/ Rated power _____		kW _____	
Klasse/ Classification _____			

All jet fans have a so-called main airflow direction. The power consumption as well as the sound pressure level is lower in this blow direction than in the reverse direction. This main airflow direction is marked with an arrow for correct mounting in tunnel.

## 14.5 Operation: Starting, stopping/ reversal

**START** Jet fans have a run-up time of less than 10 seconds depending on the type, size, background speed and voltage drop during the start phase. After this time period, the jet fan must reach its rated speed – if this is not the case, it must be switched off and the reason for longer run-up time must be determined.

**STOP/REVERSAL** Here, we have to distinguish between normal case and in case of fire: In normal case, a time period of at least 2 minutes must exist between the switching off and renewed starting in the opposite direction (allowed only for reversible jet fans!). Only in an emergency situation (in case of fire), it must be started after 20 seconds again in the opposite direction.

## 14.6 Operational safety (In addition to the already mentioned General instructions, the following instructions are applicable)

### NECESSARY SAFETY CHECKS (latest every 6 months, more often at the beginning)

Since the fans operate close to persons and can be easily damaged, they must be inspected for external damages at least every 6 months, more often at the beginning. All damaged parts must be exchanged immediately. The vibration level is to be inspected according to VDI 2056 / ISO 2372 in horizontal radial, horizontal axial and vertical radial direction at measuring points that are marked during first measurement. By comparing the measured values over a longer period of time, changes can be observed. If the values change distinctly, the causes must be investigated, for e.g. dirt on the impeller. If necessary, cleaning and rebalancing must be undertaken. Increased vibration values can lead to destruction of the fan, they represent grave risk to persons and exclude warranty from our side. Vibrations can lead to loosening of ceiling fastening. In case of increased danger due to dirt, the inspection and cleaning must be undertaken more often (especially for fans/ Vibration dampers made of stainless steel, must be freed from all deposits of corroded particles from the surface). The maintenance frequency has to be adapted to the local situation (humidity, pollutants etc.), that may result in greater frequency.

## 14.7 Recommended safety checks

### VISUAL INSPECTION (At least every six months, more often at the beginning)

Proper inspection for damage and corrosion of silencers, impeller, inlet cone, motor, cable, connections, suspension and vibration dampers. Damages, especially damages to the surface protection, must be eliminated, before the damage becomes worse.

### NOISE CHECK (every 6 months, more often at the beginning)

The smooth functioning can be ascertained by checking noise and heating. The noises generated at the start and while stopping can be compared with those of similar fans.

### INSPECTION OF MOUNTING (Every 6 months, more often at the beginning)

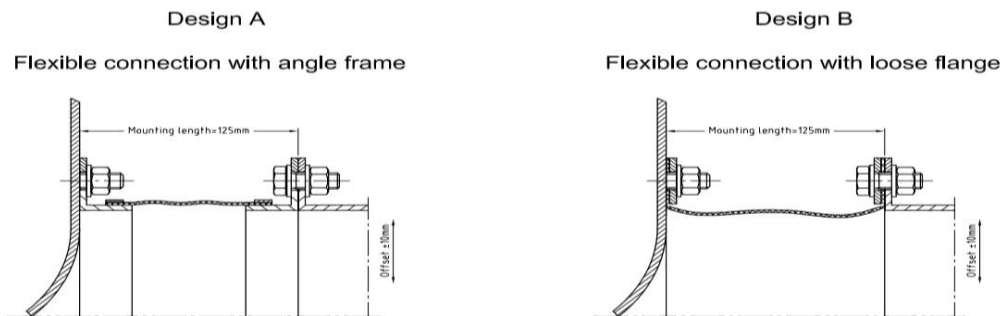
Careful inspection of all bearing parts and screw connections. All nuts must be secured against loosening and fixed with correct torque. Damaged surface protection at the screw connections should be rectified.

## 15. INSTALLATION AND MOUNTING INSTRUCTION FOR ELASTIC CONNECTIONS

Elastic connections in ventilation plants are used for movement between the duct system (stationary) and the fan (on resilient mount). The limits of elastic material given below are to be adhered to.

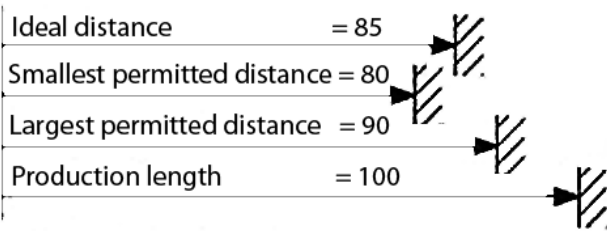
### Measurements, Tolerances

#### Chart No 21 – part 1:

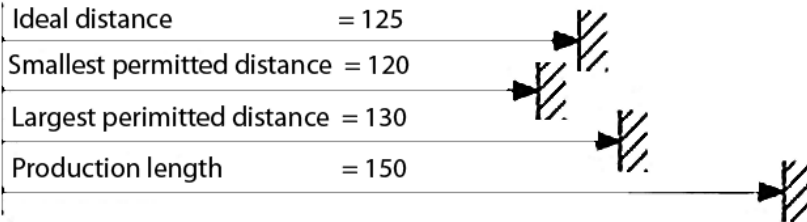


**Chart No 21 – part 2:**

**Up to size <200**



**From size 200 to 1800**



**Mounting**

At the site (mounting instruction), it must be ensured that the connection is not twisted and the screw holes are in line on the flanges of fan and duct. The screw ends of the fastening must point away from the connection such that the fabric is not damaged by the screws.

If welds-studs are used the torque is reduced according to table Torque Figure (page 24).

During mounting on threaded stud bolts, for e.g. cap nuts in accordance with DIN 1587, must be used.

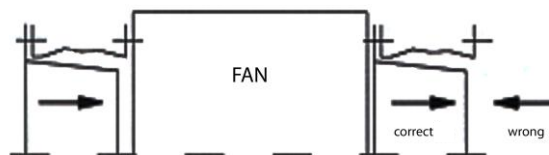
The flexible connections must be protected against damage, for e.g. welding, stepping-on, sharp objects, solvents. A cover or insulation should be provided only if this was agreed upon earlier (heat accumulation). Coat of paint is not allowed.

**Transport, storage**

The corners and edges of design A are prone to damage in the crumpled state. Therefore, transport and storage must be undertaken in a stretched condition. In case of design B, connections and backing flange need to be supplied separately. It must be kept packed in the uninstalled state in case of longer storage period.

**Chart No 22:**

Guide ducts (when provided)



Ensure proper direction of air! Air must blow into the cone, otherwise, additional flow losses may occur.

**16. OPERATING INSTRUCTION MANUAL User information  
VANE CONTROLLER for radial fans with manual adjustment and actuation**

**16.1 Special safety aspects for vane controllers**

We have carefully manufactured a solid and reliable device for you. It matches with the state-of-the-art technology.

Material and personnel damages can result from insufficient maintenance. Increased vibrations can lead to fatigue and subsequent damages.

Caution is necessary in the area of movable parts. This is applicable especially for guide vane blades and the driving- and/or actuating organs. Ascertain the fine adjustment in order to avoid unexpected adjustment.

**16.2 Installation**

Ensure that the casing is not deformed mechanically or twisted in order to avoid jamming of vane blades or damage to components. Vane controllers must be mounted only in the direction of rotation for which they were ordered and designed. Please check whether the air flow through the vane controller has a rotational component with same sense of direction as that of the impeller (so-called twisting together). All movable parts as well as actuation- and monitoring devices must be protected against corrosion, dirt and icing up.

The centrifugal vane control must be installed in the inlet of the fan. Steering heaviness of blades or of adjusting ring lead to increase power consumption of actuator. An inlet nozzle with protection grill is to be provided for free suction. The fan and the jack must be placed on rubber-bonded metal bumpers for the design with compensator. Pipe ducts in front of the inlet vane must run in a straight line on a stretch of about 2,5 times the  $\varnothing$  the nominal value in order to avoid cross-flows and turbulences and the fluctuations caused thereof.

Installations directly in front or behind the inlet vane control are to be avoided. If this is required for the functioning of the system, then, the manufacturer of the vane controller must be informed in writing even when ordering.

**16.3 Commissioning**

Fan casing and duct lines are to be checked for foreign bodies before commissioning the fan. The sense of direction is marked on the fan casing with an arrow. The correctness of sense of rotation is to be verified by switching on for a short time and observing the movable parts. The power consumption is to be measured and compared with the nominal current of motor.

Vane controllers always produce interferences in flow, fluctuations and noises.

During the start-up phase, the angle of the vane blade must be adjusted step by step in order to determine the natural oscillations of vane controller. Adjusting angles with oscillation speeds  $\geq 11$  mm/s are passed through quickly during operation or must be blocked. Volume flow throttling, in long-term operation  $\geq 10$  min, above  $75^\circ$  ( $\dot{V}_{\min} \leq 0,25 \dot{V}_{\text{nominal}}$ ) must be avoided.

#### 16.4 Functioning

The vane controller is designed for a pressure load of +20% specified in the data sheet. The regulating range is dependent on the fan- characteristic and the operating point of the plant and fan. The current power requirement changes with the setting angle of the vane controller. It is always smaller than the power requirement of fan- characteristic curve.

The driving of vane controller can take place by manual adjustment or via actuators. Up to 35% energy losses can be saved with a vane controller. During vane regulation, the fan-characteristic curve changes while additional resistances are produced during throttle regulation and thus, changes the plant characteristic curve.

**ATTENTION:** Vane controllers produce – other than in the fully opened state- considerable turbulence that can cause considerable oscillations while entry in the impeller. In order to reduce the fluctuation load, especially for high motor performances, the regulating range must be set as fine as possible.

#### 16.5 Maintenance

The smooth movement of vane controller parts and the device for arresting the hand lever are to be inspected. This should be done at least every 6 months. The bearing must be provided with self-lubricating bushes so that re-greasing is not required. During painting, care has to be taken that the paint does not adversely affect the movement of the flaps and the control devices. For all other bearings, the specified regreasing time periods must be maintained. Care has to be taken that every bearing has a limited life expectancy.

Check spherical heads and joint rods for movement and also damage and deformation. Worn out blade bearings and joint rods and roller bearings lead to increased vibrations and thus, fatigue. Mechanical, electrical or pneumatic control drives are to be checked.

## 17. FIRE DAMPERS/ SHUT-OFF-DAMPER

#### 17.1 SPECIAL SAFETY ASPECTS OF FIRE DAMPERS/ SHUT-OFF-DAMPER

We have carefully manufactured a solid and reliable device for you. It matches with the state-of-the art technology. Material and personnel damages can result from insufficient maintenance. Increased vibrations and dirt can especially lead to damages.

Caution is necessary in the area of movable parts. This is applicable for the blades as well as for drive- and actuating devices. During non-functioning of damper blade, the blade can move unexpectedly due to its inherent weight, wind or air flow

#### 17.2 TRANSPORT

During transport, the fastening slings are put through the eye holes provided for them. While using forklift trucks, the forks should not damage the activation devices. The putting down must take place with the smallest possible lowering speed. Impact shocks, rattling and falling can lead to deformation.

#### 17.3 INSTALLATION

Ensure that the casing is not deformed mechanically or twisted in order to avoid jamming of vane blades or damage to components. Fire dampers should be mounted only in the installation position for which they have been ordered and set-up (horizontal or vertical). All movable parts as well as actuation- and monitoring devices must be protected against corrosion, salt and icing up.

#### 17.4 FUNCTIONING and COMMISSIONING

In case of fire, the damper is closed either manually or with a fusible link with spring or by switching off the compressed air or power supply, mechanically with a spring. It must prevent the spreading of smoke and fire along the ventilation ducts. In general, the triggering temperature is set to 70°C.

Before commissioning, the casing is to be inspected for foreign bodies. The direction of activation is shown on the casing. Smooth movement can be verified by observing the rotating parts.

The activation of the damper must take place only in the flow-free state. The activation of fire damper can lead to malfunctions during the operation of inlet fans and exhaust fans. A time delay is to be provided during activation of fire dampers and fan operation. The lead time or follow-up time periods are to be found out from the manufacturer of the fan.

#### 17.5 MAINTENANCE- General

Fire dampers/ Shut-off-damper fulfill a very important function and must therefore be maintained and inspected twice a year. The bearings are made of stainless steel shaft (1.4571) which turns in a bush made of the same material with a loose fit. Lubrication is not required. An operational check must be undertaken every 6 months whereby the triggering mechanism is activated many times one after another and the quick smooth closure is checked.

The bearings are to be inspected and cleaned if dirt or crusts with salt was observed due to effect of sea water, for e.g. by washing out or with compressed air. During painting, care has to be taken that the paint does not adversely affect the movement of the flaps and the control devices. All components must be inspected for their efficiency after a fire. It must be checked whether delays can adversely affect the density or the smooth movement. The functioning of triggering device is to be carefully inspected.

#### 17.6 MAINTENANCE- SPECIAL INSTRUCTIONS

##### 17.6.1 Fire dampers/ shut-off-dampers with manual activation

The smooth movement of flap and the handle for arresting the hand lever are to be inspected. The manual operation can be provided exclusively or in addition to the automatic triggering. Additional hand operation has a hand lever with tappet profile which allows closure which is independent of the automatic triggering.

##### 17.6.2 Fire dampers / shut-off-dampers with fusible link

The fusible link melts and the fire damper is closed due to spring force when achieving the triggering temperature. The plunger pin releases the catch on the adjusting element, the damper blade falls in the closing direction and is locked by the locking pin in the "CLOSED" position

The functioning test is undertaken by pressing the red button. This brings about a thermal triggering. To check the fusible link, the inspection flap is removed and the fusible link is removed from the triggering device. In case no external damages are visible, tighten spring again and re-use the fusible link. If the fire damper is used again in the operation, a new fusible link must be used in the duct. Subsequently, the locking pin is pulled out and the hand lever is moved to the "OPEN" position. The plunger pin presses again into the catch for locking in this position.

### 17.6.3 Fire dampers/ shut-off-dampers with pneumatic opening

It is to be inspected whether the flap is closed due to spring force in case of pressure loss of compressed air cylinder. The closing can be undertaken by:

1. The temperature in the duct reaches the pre-set temperature, the valve is actuated.
2. Activation of hand valve on the fire damper.
3. Interruption of power supply of magnetic valve, i.e. through electrical temperature switches on the fire damper, halogen releaser, emergency stop switch or failure in the electrical supply.
4. Activation of main valve on the control system.
5. Leak in the compressed air supply.

The flap is closed by a spring which is in-built in the compressed air cylinder. The system pressure should be checked. It must be 6 to 10 bar.

Falling below or exceeding the operational pressure leads to malfunctioning.

The extended pneumatic cylinder rods must be cleaned at regular intervals and can be lubricated with a thin film of acid-free grease. The cylinder rod seal is made of self-lubricating material. The filters of the pneumatic air system are to be checked simultaneously for dirt and if necessary, replaced. The filter casing is to be cleaned and drained.

### 17.6.4 Fire dampers/ battery doors with electrical opening

Check whether the spring which is in-built in the servo-motor closes the flap in case of voltage loss. This can take place by:

1. The temperature in the duct reaches the pre-set temperature.
2. Switching off power supply
3. Fault in power supply

## 18. CABIN FANS

### SPECIAL SAFETY ASPECTS FOR CABIN FANS

We have carefully manufactured a solid and reliable device for you. It matches with the state-of-the art technology. Material and personnel damages can result from insufficient maintenance.

### INSTALLATION and COMMISSIONING

The installation must be undertaken on a level surface.

Before commissioning, the smooth closure must be inspected by turning the cover up till stop.

### MAINTENANCE:

The frequency of maintenance is dependent considerably on the operation, environmental conditions and required availability. The smooth movement of the closure is to be inspected. This should be done at least every 6 months. The threaded parts must be protected against corrosion and icing and are to be kept movable with Molycote. The seal rubber must be checked for embrittlement. During painting, care has to be taken that the paint does not adversely affect the movement of the hood.

## 19. BOOSTER BLOWERS FOR COMBUSTIBLE GASES

Please adhere to the "Guidelines for construction, maintenance and operation of gas compression systems with an operating pressure up to 1 bar –G6" of the Swiss Association of Gases and Water Treatment (SVGW).

All blowers are tested for functioning and leakproofness before delivery (24 hours, 250 mbar). The following controls are necessary **before commissioning** (transport damages or storage damages):

1. It is to be verified before connecting the pipelines whether any foreign bodies are in the casing.
2. Leakproofness check:  
Protect the blower against overloading during pressure tests.  
**ATTENTION!! Maximum test pressure: 250 mbar.** Higher pressures can lead to damage of casing and seal.
3. Check air gap at inlet of impeller: min. 2 mm
4. Turn the impeller by hand and listen for abnormal noises. Grinding noises can come on the air gap, on the seal and in the roller bearings.
5. Check screws
6. Check protection devices.
7. Direction of rotation: The first start of motor has to be undertaken only for a short while for checking the direction of rotation. For blowers that are directly driven, the direction of rotation on the motor blower can be checked. Compare the direction of rotation with the arrow on the casing. If the direction is wrong, the motor connection is to be checked.

If the blower is used after prolonged intermediate storage, the seals and the bearing must be carefully checked.

Necessary repairs must be undertaken only by the manufacturer or his authorized personnel.

During the operation, the leakproofness must be checked regularly with suitable means.

### Revision:

In order to ensure proper operation of blower, the next maintenance must be undertaken after 20,000 hours of operation, or latest after 36 months. If the environmental temperature lies above 30°C over a longer period of time or the storage temperature exceeds 70°C, this time period is reduced. The environmental temperature should not exceed 40°C. Revisions on the booster blowers must be undertaken exclusively by the manufacturer or his authorized personnel. A label (red sticker) with date (month / year) of the last revision is pasted on the blower casing.

## 20. FANS WITH MOTOR-COUPLING- FAN SHAFT

### Radial- fans Design 5 and other designs with motor- coupling- fan shaft

The careful alignment undertaken in the factory of both the shafts with regard to height displacement, lateral displacement and angular error can be disturbed at the site of installation. The coupling can compensate relatively large errors. In this case, there are forces on the shafts and bearing which lead to considerably increased vibrations, especially at high power and speeds. The frequency of these vibrations corresponds to the second harmonic of the orbital frequency and can be well differentiated from imbalance.

The fan bases can be deformed during transport or installation, for e.g. due to unevenness of ground. Therefore, alignment must be mostly tuned up. In case of high expectations regarding smooth run and life expectancy of bearing, we recommend you to undertake the alignment of shafts with each other with optical laser devices, especially at high power and speeds. This must be undertaken before commissioning and repeated periodically if necessary. The drive motor and/or the bearing must be relined up till the vibration values of the second harmonic fall below the permissible value.

Speed[1/min]	Per 100 mm of coupling diameter [1/100 mm]	
	Parallel displacement	Differences in column width (angular error)
750	9	9
1500	6	5
3000	3	2.5
6000	2	1.5
n	$1340 * n^{-0,75}$	$2950 * n^{-0,88}$

**Couplings**  
Recommended alignment tolerances,  
If not specified otherwise.

## 21. NON-ABRASIVE BLOWER HEADS

These do not have any movable parts and do not require any special maintenance. Check the protection grill available in most cases at appropriate distances and if necessary, rectify.

### 21.1 BLOWER HEADS WITHOUT FAN

Protection grills are to be inspected at appropriate distances and rectified if need be.

Water-tight, closed blower heads have movable parts, their functioning can be restricted due to dirt, salt deposits or corrosion. They are to be inspected by regular activation.

There are 2 basic types, both have one threaded spindle:

In the simplest design, the spindle is turned with the hood. The hood seals against rubber bulge on the duct. In another design, the spindle is turned with a handle via an angular gear. The angular gear has continuous lubrication. The handle runs in a nylon bush which should not be lubricated.

In an other design, the spindle is turned with a handle via through an angular gear. The angular gear is lubricated for life. The handle is in a nylon sleeve which is not lubricated.

This spindle is lubricated with Molycote during manufacture. If absolutely necessary, it is to be re-greased only at long time intervals. It is accessible from the side after unscrewing the protection grill. The closure mechanism should be operated only in the vertical position for a detached head.

The smooth movement of flap and the of hand lever are to be inspected. This should be done at least every 6 months. The spindle and the bearing points must be kept moving with Molycote, the seal rubber must be inspected for embrittlement. During painting, care has to be taken that the paint does not adversely affect the movement of the flaps and the control devices.

### 21.2 BLOWER HEADS WITH FAN

#### SPECIAL SAFETY ASPECTS FOR BLOWER HEADS

Damages to property and persons can result due to insufficient maintenance. Defective bearings and excessive vibrations can lead especially to fatigue and subsequent damages.

#### TRANSPORT

During transport with a crane, the fastening slings are to be mounted on the eye holes provided for them. In case of forklift trucks, the forks must touch below the base. The putting down must take place with the smallest possible lowering speed. Jerking and rattling can lead to imbalances and deformation.

#### INSTALLATION

The substructure must be even so that the ducts are not mechanically deformed or tightly wound in order to avoid abrasion of impellers.

The electrical installation must be undertaken according to the wiring diagram given in the junction box. All motors are to be protected with motor protective devices. Moreover, adhere to Chapter 6 (Electric motors) and if necessary, Chapter 8.3 (Ex-protection).

#### COMMISSIONING

Fan casing and duct lines are to be checked for foreign bodies before commissioning the fan. The sense of direction is to be marked on the fan casing with an arrow. The correctness of sense of rotation is to be verified by switching on for a short time and observing the movable parts. If it is wrong, then, the power connections are to be reconnected. The power consumption is to be measured and compared with the nominal current of motor.

Special care is required if the blower head with fan and motor is set up for the operation with explosive gases. To avoid danger of burning, no rust or rust film can form in the components and no iron oxide-contained and light metal-contained paints can be used.

Additional measures by local or legal requirements, standards, guidelines or edicts have to be followed. The specified distance between the rotating and stationary parts was maintained during the construction of fan. In case of imbalance and abnormal fluctuations and also after dismantling and re-mounting of impeller, a check needs to be undertaken.

#### MEASURES FOR STORAGE and for MAINTENANCE-, MOUNTING- AND STANDSTILL TIME PERIODS

Ensure that there is protection against humidity and dust. Severely fluctuating temperatures are to be avoided. If this is not sufficiently ensured, damages can occur to the electric motors, junction boxes, bearings and seals.

The lubricating capacity of grease or oil can get restricted due to stoppage. It can lead to rust formation on the bearings. Therefore, the fan must be put into operation for about 10 minutes every 1-2 months, at least, the impeller is to be turned.

#### MAINTENANCE

The frequency of maintenance is dependent mainly on the operation, environmental conditions and the required availability. It must be specified by the operator in connection with the entire plant concept with respect to the specifications made by us.

**22.1 Commissioning protocol (attention, required details for damage claim!) Download from: [www.wittfan.de](http://www.wittfan.de) Downloads/Documentation**

Project name	Machine Number:	FAN TYPE			Maintenance No.	
		AXIAL	JET	RADIAL	EXAMINER	DATE
<b>MEASURE</b>						
<b>First inspection</b>						
- Inspection for transport damage		X	X	X		
- Inspection of completeness		X	X	X		
<b>Inspection after installation</b>						
- flex. connection not damaged		X		X		
- Vibration attenuator correctly adjusted		X	X	X		
- Alignment belt disk correct				X		
- Alignment of coupling correct				X		
- Safe installation guaranteed		X		X		
- Safe mounting guaranteed			X			
- All screw connections on the suspension construction tightened with correct torque			X			
- All screw connections on the fan tightened with correct torque		X	X	X		
- Safety wires/ chains mounted with a maximum slack of about 10mm			X			
- Damaged paint repaired		X	X	X		
- All safety measures verified		X	X	X		
- Protective conductor and bonding terminals connected, function ensured		X	X	X		
<b>Inspection at taking into operation</b>						
- All safety measures verified		X	X	X		
- Tension of belt drive checked				X		
- Function of bearing analyser checked		X	X	X		
- Function of vibration monitor checked		X	X	X		
- Function of tear-off control checked			X			
- Direction of rotation checked		X	X	X		
- Vibration level at the bearing motor meas. horizontal / vertical / axial .....mm/s      mm/s      mm/s	max. between 4,5 to 7,1 mm/s acc. To ISO 14694/ ISO 10816-3	X	X	X		
- Sound pressure level measured (1 or 3m / 45° from the inlet) .....dB(A) in ..... meters		X	X	X		
- Frequency converter drive (yes/ no / TYPE)		X	X	X		
- Electrical values recorded Voltage / Frequency .....V / ..... Hz Current Phase U / V / W ..... A / ..... A / ..... A		X	X	X		

**22.2 Status- and maintenance protocol(attention, required details for damage claim!) Download under: [www.wittfan.de](http://www.wittfan.de) Downloads/Documentation**

Project name	Machine Number:	FAN TYPE			Maintenance No.	
		AXIAL	JET	RADIAL	EXAMINER	DATE
<b>MEASURE</b>						
<b>Maintenance ( every 6 months)</b>						
- Bearing checked/ relubricated		X	X	X		
- Shaft sealing checked/ relubricated				X		
- Belt tension checked				X		
- Flexible connections checked		X		X		
- Starting-up coupling checked				X		
- Coupling checked (Alignment/ rubber elements)				X		
- Radial vane mobility of blades checked		X		X		
- Vibration level at the motor B-bearing measured horizontal / vertical / axial .....mm/s      mm/s      mm/s		X	X	X		
- Vibration level at the casing measured horizontal / vertical / axial .....mm/s      mm/s      mm/s	≤ 4,5 mm/s : good ≥ 9,0 mm/s : alarm ≥ 12,5 mm/s : trip/ shutdown	X	X	X		
- Sound pressure level measured (1 or 3 m / 45° from the inlet) .....dB(A) in .....meters		X	X	X		
- Electrical values recorded voltage / Frequency.....V / ..... Hz Current Phase U / V / W ..... A / ..... A / ..... A		X	X	X		
- Visual check for corrosion (possible repair paint damage) - Fan - Vibration attenuator - Impeller		X	X	X		
- Visual check for corrosion - Motor		X	X	X		
damages checked - Fan - Vibration attenuator - Impeller		X	X	X		
- Check all screw connection suspension construction (see chapter 14.2)			X			
- Check the suspension structure for signs of fatigue / cracks (see chapter 5.8)			X			
- Check all screw connections at the fan		X	X	X		
- Check catch device/ catch rope			X			
- Insulation check at the warm motor (Resistance in between winding and earth at 500 V DC) ..... MegaOhm		X	X	X		
- If stainless steel fan/-silencer -> all kind of corroding particles sticking to the surface removed		X	X	X		
- Function of vibration monitor checked Vibration values horizontal / vertical / axial ..... mm/s .....mm/s .....mm/s		X	X	X		
- E-Kit of tear-off –safety checked			X			

**23. Fundamental safety instructions**  
for products and components of the WITT GROUP companies

**23.1 Principle; Intended use**

The machine/plant is built according to the state-of-the-art technology and the recognized safety-technical rules. Nevertheless, there is danger to life and limb of user or a third party or damages to machine and other material property during its usage.

Use machine/ plant only in technically faultless state as well as according to regulation, being conscious of safety and danger with regard to the operating instruction manual! Immediately rectify interferences that can adversely affect the security!

Even the adherence to the operating instruction manual and the inspection- and maintenance conditions is part of intended use.

**23.2 Organizational measures**

In addition to operating instructions, general legal and other contractual regulations are to be adhered to and directed for prevention of accidents and for environmental protection!

The operation and maintenance manual must be complemented with duties inclusive of surveillance duties and reporting duties taking into consideration the operational features, for e.g. with regard to work organization, work sequences, personnel employed.

The personnel assigned to work on the machine must have read the operating instruction manual, and especially the chapter on Safety instructions before beginning the work. It would be too late during the working. This especially applies in considerable measure to personnel working only occasionally, say, during set-up, maintenance.

Check at least from time to time the personnel carrying out work in compliance with the operating instruction manual!

The personnel should not have long hair, loose clothing or jewellery including rings. There is risk of injury, for e.g. due to getting caught or pulling in.

If necessary or required by rules, use personal protective equipment!

Adhere to all safety- and procedural instructions on the machine/ plant!

All safety- and procedural instructions on/at the machine must be fully legible!

In case of safety-relevant changes, the machine/ plant or its operation must be stopped immediately and report the malfunction to the concerned site/person!

No changes, additions and conversions to the machine/ plant that can adversely affect the safety, can be undertaken without the permission of the supplier! This applies also for the installation and setting of safety devices and -valves as well as for welding on bearing parts.

Spare parts must match with the technical requirements fixed by the manufacturer. This is always guaranteed for original spare parts.

Never modify programs (software) of programmable control systems!

Replace hydraulic- pipelines in the stipulated or at appropriate time intervals, even if no safety-relevant defects have been detected!

Adhere to prescribed intervals or intervals specified in the operation and maintenance manual for routine test/inspections!

For implementation of maintenance measures, workshop equipment for work is definitely required.

**23.3 Selection of personnel and qualification; Basic duties**

Work on the machine/plant must be undertaken only by reliable personnel. Adhere to legally permissible minimum age!

Employ only trained or instructed personnel, fix clearly the responsibilities of the personnel for operation, set-up, maintenance and repair work!

Ensure that only authorized personnel work on the machine!

Work on the electrical devices of machine/ plant must be undertaken only by a skilled electrician or by instructed persons under the

supervision and guidance of a skilled electrician in accordance with the electro-technical rules.

Working on gas-technical devices (gas consuming devices) must be undertaken only by trained personnel.

Work on hydraulic systems must be carried out only by personnel with specialized knowledge and experience in hydraulics!

**23.4 Safety instructions for certain specific operational phases****23.4.1 Standard operation**

Avoid any operational mode that might be prejudicial to safety!

Take measures by which the machine/plant is operated only in safe and reliable state!

Operate machine only when all protective devices and safety-conditioned devices, say, detachable protective devices, emergency-off- devices, sound protection, exhaust, are available and are functional!

Check the machine/plant for easily recognizable damages at least once per shift! Report changes occurred (including those of operational behaviour) immediately to the concerned site/person! If necessary, stop the machine immediately and lock it!

Stop the machine/plant immediately in case of malfunctions and lock it! Rectify defects immediately!

Ensure start-up and switch-off processes, control indicators in accordance with the operating instruction manual!

Ensure that nobody is at risk during the running of the machine/ plant before switching-on/ setting the machine in operation!

Do not switch off or remove suction- and ventilation devices when the machine is in operation!

**23.5 Special work within the scope of usage of machine/ plant and maintenance activities and also repairs during working; disposal**

Adhere to the setting-, maintenance- and inspection activities and – schedules given in the operating instruction manual including specifications about replacement of parts/ equipment! These activities must be undertaken only by technical personnel.

Inform operating personnel about the special- and maintenance work before the beginning of work! Appoint supervisors!

For all work involving operation, production adjustment, provision or setting-up of machine/plant and their safety-conditioned devices and also inspection, maintenance and repairs, switch-on and switch-off processes must be ensured according to the operating and maintenance manual and instructions for maintenance work!

Ensure that the maintenance area is spacious, if necessary!

If the machine/ plant is completely shut down during maintenance and repairs, it must be secured against accidental switching on:

- Close main control devices and remove keys and/or
- put up warning sign on the main switch.

Individual parts and larger components are to be fixed carefully on the hoists during replacement and to ensure that there is no danger. Use only suitable and technically faultless hoists as well as load suspension devices with sufficient lifting capacity! Never stand or work under suspended loads!

Employ only experienced personnel with the fastening of loads and supervision of crane operators! The supervisor must be within the sight of operator or must be able to communicate with him.

During mounting work over the heads, use specially designed ladders or working platforms. Do not use machine parts as a climbing aid! Wear safety harness during maintenance work at greater heights!

All handles, steps, handrails, platforms, landings, ladders must be free from dirt, snow and ice!

Before cleaning the machine with water or steam jet (high pressure cleanser) or other cleansing agents, cover/ tape up all openings for security - and/or functional reasons so that water/steam/detergents do not penetrate in. Electric motors and switchboards must be specially protected.

Ensure during cleaning work of machine that the temperature sensor of the fire-warning- and fire-extinguishing systems does not come in contact with hot detergents. This can activate the fire-extinguishing system.

After cleansing, remove all covers/ tapes completely!

After cleaning, all fuel-, motor oil-, hydraulic oil- pipes are to be inspected for leakage, loose connections, chafe marks and damages! Defects found must be rectified immediately!

Tighten loose screw connections constantly during maintenance and repairs!

If the dismantling of safety devices is required during set-up, maintenance or repair work, the re-mounting and inspection of safety devices must be undertaken after completion of maintenance and repairs.

Cater to the secure and environmental-friendly disposal of equipment and auxiliary material!

## 23.6 Instructions regarding special types of dangers

### 23.6.1 Electrical energy

Use only original fuses with specified current rating! Switch off the machine/plant immediately in case of interruptions in the electrical power supply!

Work on electrical devices or equipment must be undertaken only by a skilled electrician or by instructed personnel under the supervision of a skilled electrician in accordance with the electro-technical rules.

Machine parts on which inspection, maintenance and repairs must be undertaken, must be disconnected – if prescribed. The de-energized parts must be inspected firstly for disconnection, then, ground them and short-circuit them and also insulate live parts!

Inspect/ check electrical equipment of machine regularly. Defects such as loose connections or scorched cables, must be rectified immediately.

If work is required on live parts, a second person who can activate the emergency- off- or main switch in case of emergency needs to get involved. Secure work area with a red-white safety chain and warning sign. Use only insulated tools!

Connect the feeder cable to the ground while working on high voltage components after cutting off voltage and short-circuit the components, for e.g. capacitors with a grounding rod!

### 23.6.2 Gas, dust, steam, smoke

Welding, flame-cutting and grinding work on the machine can be undertaken only this has been explicitly permitted. There is risk of fire and explosion!

Before welding, flame-cutting and grinding, clean machine and its surroundings, free from dust and combustible material and ensure sufficient ventilation (Risk of explosion)!

Observe all national regulations if work is to be carried out narrow rooms!

### 23.6.3 Hydraulics, pneumatics

Work on hydraulic equipment must be undertaken only by persons with special knowledge and experience in hydraulics!

All pipes, ducts and connections are to be inspected regularly for leakage and obvious damages! Rectify damages immediately! Splashed oil can lead to injury and fires.

Depressurize all system sections to be opened and pressurized pipes (hydraulic, compressed air) before beginning repair work according to the descriptions of components!

Lay hydraulic- and compressed air pipelines properly and mount them! Do not interchange connections! Armature, length and quality of pipelines must comply with the requirements.

### 23.6.4 Noise

All sound-protecting devices on the machine must be in closed position during the operation.

Wear prescribed ear protection!

### 23.6.5 Oils, grease and other chemical substances

When handling oil, grease and other chemical substances, adhere to the safety instructions applicable for the product!

Caution while handling hot equipment and auxiliary material (risk of burning or scalding)!

### 23.7 Portable machines (Machines used at different locations)

Use only hoists and load suspending devices with sufficient lifting capacity during loading work!

Appoint an expert for the hoisting work!

Lift machines properly with hoists only in accordance with the specifications of operating instruction manual (fixing point for load suspending devices etc.)!

Use only suitable transport vehicle with sufficient lifting capacity!

Ensure reliable loading. Use suitable fixing points!

Equip machine with recommended/supplied devices against unintentional change in position before or directly at the end of loading work! Put up appropriate warning sign!

Properly remove devices before re-commissioning!

Carefully re-mount the parts that were dismantled for transport purposes before re-commissioning and fix them!

Disconnect the machine or plant from any external energy supply even for minor change in location! Connect the machine again properly to the mains before re-commissioning!

Proceed in accordance with the operating instruction before re-commissioning!

#### Trade marks:

Banana Jet®  
Christmas Tree®

Trademark with device:

**WITT GROUP** **WITT GROUP** **WITT GROUP** **WITT GROUP**  
Witt & Sohn AG , MEIDINGER AG , Fan Systems , Witt India Pvt. Ltd.